

NORTH COUNTY FIRE PROTECTION DISTRICT

330 S. Main Avenue • Fallbrook, California 92028-2938 • Phone: (760) 723-2005 • Fax: (760) 723-2072 • Web: www.ncfire.org

BOARD OF DIRECTORS

CINDY ACOSTA
JEFFERY EGKAN
DAVID KENNEDY
KENNETH E. MUNSON
JOHN VAN DOORN

KEITH MCREYNOLDS - Fire Chief/CEO - kmcreynolds@ncfire.org
ROBERT H. JAMES - District Counsel - roberthjameslaw@gmail.com
LOREN A. STEPHEN-PORTER - Executive Assistant/Board Secretary - lstephen@ncfire.org

TO: BOARD OF DIRECTORS
FROM: KEITH MCREYNOLDS, FIRE CHIEF/CEO
SUBJECT: BOARD MEETING PACKAGE
DATE: May 24, 2022

Enclosed is your Board package for the Regular May Board Meeting. We have tried to include the information you will need to effectively consider and act on agenda items. The Board meeting will be held at the regular meeting venue at **FALLBROOK PUBLIC UTILITY DISTRICT, 990 EAST MISSION ROAD, FALLBROOK, CALIFORNIA.**

Please note this month's meeting is scheduled for Tuesday, May 24, 2022, beginning at **4:00 p.m.**

It is our goal to be prepared to respond accurately to Board questions and concerns. You can help us achieve this goal by contacting me prior to the Board meeting with your questions and concerns. This will allow time for the Staff and me to provide the appropriate information for review at the Board meeting.

To ensure a quorum is present, please call Loren in advance of the meeting if you will be unable to attend. She may be reached at (760) 723-2012.

Respectfully,



Keith McReynolds
Fire Chief/CEO



PROUDLY SERVING THE COMMUNITIES OF FALLBROOK, BONSALE AND RAINBOW

DUTY ~ INTEGRITY ~ RESPECT

PAGE INTENTIONALLY BLANK



NORTH COUNTY FIRE PROTECTION DISTRICT

AGENDA FOR REGULAR BOARD MEETING

MAY 24, 2022 — 4:00 p.m.

**FALLBROOK PUBLIC UTILITY DISTRICT
990 EAST MISSION ROAD
FALLBROOK CALIFORNIA**

LOCATION:

The May 24, 2022 meeting will be available via Zoom. The public may attend remotely using either:

The Zoom app, Zoom website (<https://zoom.us/>) [Meeting ID: 870 1784 6503; Passcode: 631628] at <https://us06web.zoom.us/j/87017846503?pwd=ekF0RGt1Mm4vWXgrRFpXbUIPUFlmdz09> or Dial by your location: +1 669 900 6833 US (San Jose); Meeting ID: 870 1784 6503; Passcode: 631628

The public may provide comments in advance or real-time by emailing ncfboardcomments@ncfire.org. E-mailed comments received will be read into the record by Staff.

PUBLIC ACTIVITIES AGENDA

For those joining us for the Public Activities Agenda, please feel free to depart at the close of the agenda. We invite you to stay for the remainder of the business meeting.

CALL TO ORDER ROLL CALL INVOCATION PLEDGE OF ALLEGIANCE

1. PUBLIC COMMENT — PRESIDENT EGKAN

(pgs. 7-8)

- **STANDING EVENT:** Members of the Public may directly address the Board of Directors on items of interest to the Public provided no action will be taken on non-agenda items. The Board President may limit comments to three minutes per speaker (Board of Directors Operations – Elections, Officers and Terms SOG § 4.2.6.3.).

ACTION AGENDA

CONSENT EVENTS:

All Events listed under the Consent Events are considered routine and will be enacted in one motion. There will be no separate discussion of these Events prior to the Board action on the motion, unless members of the Board, Staff or public request specific Events be removed from the Consent Agenda.

2. APPROVE REGULAR BOARD MEETING MINUTES, APRIL 2022

(pgs. 9-16)

- **Standing Event:** Review and approve minutes from April meeting as presented.

3. REVIEW AND ACCEPT FINANCIAL REPORT FOR APRIL 2022

(pgs. 17-26)

- **Standing Event:** Review and accept Financial Report for April as presented.

4. REVIEW AND ACCEPT POLICIES & PROCEDURES

(pgs. 27-50)

- **Standing Event:**

- Employee Physical Exams - Rules & Regulations – Conditions of Employment: Revision to reflect current practice and vendor.
- Physical Ability Examination - Rules & Regulations – Conditions of Employment: Policy updated to meet current practice for return to work.

5. MONTHLY OPERATIONS ACTIVITY REPORT – APRIL 2022

(pgs. 51-60)

- **STANDING EVENT:** Monthly Report demonstrating Call Mix, Turnout Time, Call by Unit, Transports, Total Response Times, Aid Received & Provided, Monthly Inspection Report, Health & Safety – Injuries & Accidents and Turnover of Care statistics.

Note: The Americans with Disabilities Act provides that no qualified individual with a disability shall be excluded from participation in, or denied the benefits of, District business. If you need assistance to participate in this meeting, please contact the District Office 72 hours prior to the meeting at (760) 723-2012.



AGENDA FOR REGULAR BOARD MEETING

MAY 24, 2022

PAGE 2 OF 4

ACTION EVENTS:

All Events listed under the Action Events Agenda will be presented and discussed prior to the Board taking action on any matter. Time Certain Events will commence precisely at the time announced in the Agenda.

6. **REVIEW AND CONSIDER TRANSITION OF THE DISTRICT'S PROPERTY/LIABILITY CARRIER — DFC MAHR AND CHIEF McREYNOLDS** (pgs. 63-106)
➤ New Item: Consider transition from SDRMA to Emergency Services Insurance Program (ESIP).
7. **SET PUBLIC HEARING DATE/TIME CERTAIN JULY 26, 2022 (4:05 P.M.) — ADOPTING A RESOLUTION ESTABLISHING A MULTI-YEAR FACILITIES AND EQUIPMENT PLAN FOR THE FIRE MITIGATION PROGRAM — FM FIERI AND CHIEF McREYNOLDS** (pgs. 107-108)
➤ Annual Item: Recommendation to set required Public Hearing, date and times certain on July 26, 2022 for hearing as outlined.
8. **REVIEW AND APPROVE/AUTHORIZE FIXED CHARGE SPECIAL ASSESSMENT FOR WEED ABATEMENT – FIRST READING — FM FIERI AND CHIEF McREYNOLDS** (pgs. 109-162)
➤ Annual Item: Approve and authorize Staff to deliver fixed Charge Assessment to County when deadlines are met.
9. **APPROVE AND AUTHORIZE STAFF TO EXECUTE A CONTRACT FOR STATION 2 FACILITY MAINTENANCE PROJECT — D/C MACMILLAN AND CHIEF McREYNOLDS** (pgs. 163-164)
➤ New Item: Approve and authorize Staff to execute a contract for Station 2 Maintenance Project with Reed Family Enterprises, Inc.
10. **APPROVE AND AUTHORIZE STAFF TO EXECUTE A CONTRACT FOR STATION 3 RENOVATION CONSTRUCTION MANAGEMENT SERVICES — CHIEF McREYNOLDS** (pgs. 165-166)
➤ New Item: Approve and authorize Staff to execute a contract for Station 3 Renovation Construction Management Services with Erickson Hall Construction.

DISCUSSION AGENDA

No action shall be undertaken on any Discussion Event. The Board may: acknowledge receipt of the information or report and make comments; refer the matter to Staff for further study or report; or refer the matter to a future agenda.

11. **DISCUSSION/REPORT ON BLS AMBULANCE TRIAL — DFC MAHR AND CHIEF McREYNOLDS** (pgs. 167-168)
➤ Follow-Up Report: Report on status of BLS Ambulance trial.
12. **DISCUSSION ON PRELIMINARY BUDGET — FINANCE MANAGER JUUL AND CHIEF McREYNOLDS** (pgs. 169-174)
➤ Annual Item: Discussion of Preliminary Budget and of any changes in Budget process.

STANDING DISCUSSION EVENTS: All Events listed under the Standing Discussion Events are presented every meeting.

- **LEGAL COUNSEL REPORT:** (pgs. 175-176)
 - "Will Virtual Public Meetings Continue Even After the Pandemic?"
- **WRITTEN COMMUNICATION:** None (pgs. 177-178)
 - BOARD RECOGNITION PROGRAM
- **NEWS ARTICLES:** As attached. (pgs. 179-198)



NORTH COUNTY FIRE PROTECTION DISTRICT

AGENDA FOR REGULAR BOARD MEETING

MAY 24, 2022 — 4:00 p.m.

ADJOURNMENT

SCHEDULED MEETINGS

The next regularly scheduled Board meeting is: Tuesday, **June 28, 2022**, 4:00 p.m.

CERTIFICATION OF AGENDA POSTING

"I certify that this Agenda was posted in accordance with the provisions of the Government Code § 54950 et. seq. The posting locations were: [1] the entrance of North County Fire Protection District Administrative Offices, [2] Fallbrook Public Utility District Administrative Offices and [3] the Roy Noon Meeting Hall; [4] District's website at <https://www.ncfire.org>. The Agenda was also available for review at the Office of the Board Secretary, located at located at 330 S. Main Avenue, Fallbrook (760) 723-2012. Materials related to an item on this Agenda submitted to the District after distribution of the agenda packet, are available for public inspection in the Office of the Board Secretary, located at 330 S. Main Avenue, Fallbrook (760) 723-2012, during normal business hours or may be found on the District website at <https://www.ncfire.org>, subject to the Staff's ability to post the documents before the meeting. The date of posting was **May 19, 2022.**"

Board Secretary Loren Stephen-Porter:

Loren A. Stephen-Porter

Date:

May 19, 2022



**NORTH COUNTY FIRE
PROTECTION DISTRICT
FIRE CHIEF/CEO**

TO: BOARD OF DIRECTORS
FROM: KEITH McREYNOLDS, FIRE CHIEF/CEO
DATE: MAY 24, 2022
SUBJECT: PUBLIC COMMENT

PUBLIC COMMENT:

- 1. Members of the Public may directly address the Board of Directors on items of interest to the Public provided no action will be taken on non-agenda items. The Board President may limit comments to three minutes per speaker (Board of Directors Operations – Elections, Officers and Terms SOG § 4.2.6.3.).*

PAGE INTENTIONALLY BLANK

1 **April 26, 2022**

2 **REGULAR MEETING OF THE BOARD OF DIRECTORS OF**
3 **THE NORTH COUNTY FIRE PROTECTION DISTRICT**

4 President Egan called the meeting to order at 4:00 p.m.

5 **A MOMENT OF SILENCE WAS OBSERVED.**

6 **ALL RECITED THE PLEDGE OF ALLEGIANCE.**

7 **ROLL CALL:**

8 **Present:** Directors Acosta, Egkan, Kennedy, Munson and van Doorn.

9 **Absent:** None.

10 **Staff Present:** Fire Chief/CEO McReynolds, Attorney James and Board Secretary Stephen-
11 Porter. In the audience were: DFC Mahr, D/C MacMillan, B/C DeCamp, F/M Fieri, FiM Juul
12 and members of the public and Association.

13
14 **PUBLIC ACTIVITIES AGENDA**

15 1. **PUBLIC COMMENT:** President Egan addressed the audience and inquired whether
16 there were any public comments regarding items not on the Agenda. An individual
17 requested to speak to the Board regarding defensible space. He had concerns about how
18 his neighbor and other properties around him with relation to how they were being handled
19 for weed abatement. FM Fieri explained the relationship between local agencies and how
20 LRA and SRA abatement areas are handled. The individual asked what agency to go to for
21 help with his issues because he lives in a high fire zone. FM Fieri took his information and
22 offered to contact him that week to provide information and address his concerns. There
23 being no further comments, the Public Comment Section was closed.

24 2. **FIRST QUARTER AWARDS FOR BOARD RECOGNITION PROGRAM — CHIEF McREYNOLDS AND**
25 **B/S STEPHEN-PORTER:** Chief McReynolds noted this was the District's first live stream and
26 thanked those in attendance. He presented the individuals for recognition, noting the two
27 individuals who had stopped to help pick up the trash. Each Board member discussed their
28 choice for recognition, noting the difficulty in making a limited selection from the group of
29 nominees. It was noted there was sufficient funding still to acknowledge all employees. On

30 a motion by Director Munson, seconded by President Van Doorn, the motion to acknowledge
31 all individuals as submitted passed unanimously.

32 **ACTION AGENDA**

33 **CONSENT ITEMS:**

- 34 3. **REVIEW AND ACCEPT REGULAR BOARD MEETING MINUTES FOR MARCH 2022**
- 35 4. **REVIEW AND ACCEPT FINANCIAL REPORT FOR MARCH 2022**
- 36 5. **REVIEW AND ACCEPT POLICIES & PROCEDURES**
- 37 6. **MONTHLY OPERATIONS ACTIVITY REPORT – FEBRUARY 2022**
- 38 7. **REVIEW AND ACCEPT FIRST QUARTER 2022 CUSTOMER SATISFACTION SURVEY**

39 President Egkan inquired whether there were any questions on Consent Items 3-7. There
40 being no discussion, President Egkan asked for a motion to approve the Consent Agenda.
41 On a motion by Director van Doorn and seconded by Director Kennedy, the motion to
42 approve the Consent Agenda as presented passed unanimously.
43

44 **ACTION ITEMS:**

- 45 8. **REVIEW AND APPROVE DEPUTY FIRE MARSHAL POSITION, JOB DESCRIPTION AND PLAN TO**
46 **FILL THE POSITION — CHIEF McREYNOLDS:** Chief McReynolds informed the Board that the
47 Staff had reviewed and re-evaluated what the District would require now that there is a
48 vacancy in the Community Risk Reduction Division (CRR). With the number of arson-type
49 incidents they had this year and last, it was determined there was a need to have someone
50 that could have FPS responsibilities as well as the added depth of performing investigations.
51 While the District has had the DFM position for years, it has been a Non-Safety position who
52 had no investigative responsibilities. With the exposure to toxic situations and the need to
53 have the ability to utilize safety equipment that is required for investigations, it was felt the
54 position was more appropriately a Safety position. After looking at job descriptions across
55 the state, most are Safety. It would require a change in the Safety MOU for this position.
56 Comparing salaries for like positions shows there would be a \$10,000-19,000 increase for
57 the position. Staff is looking to start the position in June. On a motion by Director Munson
58

59 and seconded by Director van Doorn, the motion to approve the DFM position to be filled by
60 June, with the revised DFM job description/salary as presented, passed unanimously.

61 9. **REVIEW AND APPROVE GRANT APPLICATION FOR NEIGHBORHOOD REINVESTMENT GRANT**
62 **AND RESOLUTION 2022-09 — DFM MAHR AND CHIEF McREYNOLDS:** DFC Mahr presented the
63 grant applicant and Resolution 2022-09 to the Board for approval, noting the request is for a
64 Pump Pod. The Pod would allow for training without the waste of water and would allow
65 engineers to flow water and perform hydraulic calculations. The Pod is on a trailer so it
66 would be able to use throughout the Zone, Discussion ensued regarding the Pod's
67 capabilities. On a motion by Vice President Acosta and seconded by Director van Doorn,
68 the motion to approve the grant application and Resolution 2022-09 allowing the District to
69 enter into a grant agreement passed unanimously.

70 10. **REVIEW AND DECLARE A CONTRACT FOR CONSULTING SERVICES WITH MICHAEL BAKER, INTL**
71 **AS A SOLE SOURCE AND DIRECT STAFF TO EXPLORE ENGAGING A REAL ESTATE CONSULTANT —**
72 **CHIEF McREYNOLDS:** Chief McReynolds presented a request to declare a consulting contract
73 with Michael Baker Intl. for continuing consulting services as a sole source and to explore
74 engaging a real estate consultant to assist with easement vacations and the
75 evaluation/potential sale for parcel 1032332300 and 1032331100. Staff would bring any
76 offer for sale of the parcels back to the Board prior to taking action. Chief McReynolds
77 discussed possible opportunities on the two properties, noting that the ball field located on
78 one of the properties will soon not be needed as there will be fields in Bonsall soon. On a
79 motion by Director Kennedy and seconded by Vice President Acosta, the motion to declare
80 a sole source and execute a contract with Michael Baker Intl. as presented and engage a
81 real estate consultant passed unanimously.

82 11. **SIGN AND SUBMIT A LETTER OF SUPPORT FOR THE SD SHERIFF STATION AND THE DISTRICT'S**
83 **INTEREST OF RELOCATING STATION 4 TO THE CENTER LOCATED NEAR 1-15 AND SR-76 — CHIEF**
84 **McREYNOLDS:** Chief McReynolds presented a letter to be sent to the County that would
85 support the SD Sheriff Station and also convey an interest by the District to relocate its
86 Station 4 to the same Center. There are 18 acres at the site and the planning committee
87 has already started its review. Chief McReynolds has met with local representatives and

88 expressed the District's interest in being involved in the center. Cal Fire has also expressed
89 an interest in being involved. On a motion by Director van Doorn and seconded by Director
90 Kennedy, the motion to approve the letter as presented and to send to Supervisor Desmond
91 expressing the Board's interest of the District's involvement passed unanimously.

92 12. **REVIEW AND APPROVE RESOLUTION 2022-10 REQUESTING THE BOARD OF EQUALIZATION**
93 **DISSOLVE NORTH COUNTY FIRE PROTECTION DISTRICT – RAINBOW ZONE [BOE 0138] INTO NORTH**
94 **COUNTY FIRE PROTECTION DISTRICT [BOE 0137] — CHIEF McREYNOLDS:** Chief McReynolds
95 presented Resolution 2022-10 and the application to be submitted to the Board of
96 Equalization (BOE) to dissolve the Rainbow Zone subaccount. This action is undertaken as
97 a result of the LAFCO MSR recommendation that the Rainbow subzone and station be fully
98 integrated into North County Fire Protection District. Currently, all the TRAs contained in
99 the Rainbow subzone [BOE0138] are contained in NCFPD's [BOE 0137]. Working with the
100 BOE, the instant Resolution has been informally reviewed and vetted for submission and
101 formal approval. On a motion by Director Kennedy and seconded by Director van Doorn,
102 the motion to approve Resolution 2022-10 and the application for submission to the BOE as
103 presented passed unanimously.

104 13. **REVIEW AND APPROVE LETTER TO SEND TO CONGRESSMAN ISSA SUPPORTING H.R. 3728 —**
105 **CHIEF McREYNOLDS:** Chief McReynolds presented a letter he is requesting the Board
106 approve for submission to Congressman Issa supporting H.R. 3728, the Fire Station
107 Construction Grants Act. It is a bill that would allocate up to 1 billion dollars in Federal
108 funding assistance for such construction. Although other fire entities may have funding
109 options, special districts are more limited in their ability to obtain Federal funding. On a
110 motion by Director Munson and seconded by Director Kennedy, the motion to approve the
111 letter as presented and sending it to Congressman Issa passed unanimously.

112 **DISCUSSION AGENDA**

113
114 14. There were no Discussion Agenda Items for the April 26, 2022, Board Meeting.

115 **STANDING DISCUSSION ITEMS:**

117 ● **LEGAL COUNSEL REPORT:** Counsel James presented his report “California Issues
118 New Drought Executive Order.” Brief discussion ensued regarding the new executive order
119 regarding the drought and water conservation. It was noted that Rainbow water is seeking
120 to add one more heli-tank. This is informational only, no action required.

121 ● **WRITTEN COMMUNICATIONS:** No discussion regarding the items. Informational
122 only, no action required.

123 ● **BOARD RECOGNITION PROGRAM** No discussion.

124 ● **NEWS ARTICLES:** No discussion regarding articles. This is informational only, no
125 action required.

126 ● **COMMENTS:**

127 ● **STAFF REPORTS/UPDATES:**

128 ● **KEITH McREYNOLDS, FIRE CHIEF/CEO:** Chief McReynolds informed the Board he and
129 others attended the Cal Chief’s Administrative section conference. He opined they all
130 learned a lot. There are currently two RFPs running for construction. Both close May 5th.
131 The Strategic Plan is nearly finished. Next week, Chief McReynolds will be attending FESDI.
132 In May, the Board should expect to see the initial Preliminary Budget discussion.
133 Informational only, no further action required.

134 ● **CHIEF OFFICERS AND OTHER STAFF: D/C MACMILLAN:** D/C Macmillan updated the Board
135 on the CCR activities, noting they have new banners to provide a visual outreach regarding
136 defensible space and drowning. The banners are reusable and have QR codes that direct
137 the public to social media sites for information. They will also be in Spanish. CCR will be
138 working with community partners to have them displayed in their areas.

139 ● **BOARD: DIRECTOR MUNSON:** Director Munson thanked everyone for their care and
140 concern regarding the passing of his wife.

141 ● **BARGAINING GROUPS:** No comments.

142 ● **PUBLIC COMMENT:** No comments.

143

144

CLOSED SESSION

145

● **OPENING CLOSED SESSION:**

146 At 5:15 p.m., President Egkan inquired whether there was a motion to adjourn to Closed
147 Session. There being no objection, President Egkan read the items to be discussed in
148 Closed Session and the Open Session was closed. A short break ensued after the reading
149 of the Closed Session Items. At 5:20 p.m., and the Board entered Closed Session to hear:
150 CS-1. **ANNOUNCEMENT — PRESIDENT EGKAN:** An announcement regarding the items to be
151 discussed in Closed Session will be made prior to the commencement of Closed Session.
152 CS-2. **CONFERENCE WITH LABOR NEGOTIATOR – GOVERNMENT CODE § 54957.6 —**
153 **MANAGEMENT GROUP NEGOTIATIONS – CHIEF McREYNOLDS:**
154 NCFPD MANAGEMENT GROUP DISTRICT NEGOTIATORS:
155 CHIEF McREYNOLDS, DISTRICT COUNSEL JAMES
156 CS-3. **CONFERENCE WITH LABOR NEGOTIATOR – GOVERNMENT CODE § 54957.6 — NON-**
157 **SAFETY GROUP NEGOTIATIONS – CHIEF McREYNOLDS:**
158 FFA NON-SAFETY GROUP NEGOTIATORS DISTRICT NEGOTIATORS:
159 CHIEF McREYNOLDS, DISTRICT COUNSEL JAMES
160 CS-4. **CONFERENCE WITH LABOR NEGOTIATOR – GOVERNMENT CODE § 54957.6 — SAFETY**
161 **GROUP NEGOTIATIONS — CHIEF McREYNOLDS:**
162 FFA SAFETY GROUP NEGOTIATORS DISTRICT NEGOTIATORS:
163 CHIEF McREYNOLDS, DISTRICT COUNSEL JAMES
164 CS-5. **EMPLOYMENT OF PUBLIC EMPLOYEE – GOVERNMENT CODE § 54957(b) – CHIEF**
165 **McREYNOLDS:**
166 EXECUTIVE ASSISTANT/BOARD SECRETARY
167 CS-6. **EMPLOYMENT OF PUBLIC EMPLOYEE – GOVERNMENT CODE § 54957(b) – CHIEF**
168 **McREYNOLDS:**
169 DISTRICT COUNSEL
170 CS-7. **REPORT FROM CLOSED SESSION — PRESIDENT EGKAN**
171 **• REOPENING OPEN SESSION:**
172 On a motion by Director van Doorn and seconded by Director Kennedy, which passed
173 unanimously, the Board returned Open Session at 6:25 p.m. the following items were
174 reported out to the public:

175 CS-2. CONFERENCE WITH LABOR NEGOTIATOR – GOVERNMENT CODE § 54957.6 –
176 MANAGEMENT GROUP NEGOTIATIONS – CHIEF McREYNOLDS: No reportable action.

177 CS-3. CONFERENCE WITH LABOR NEGOTIATOR – GOVERNMENT CODE § 54957.6 – NON-
178 SAFETY GROUP NEGOTIATIONS – CHIEF McREYNOLDS: On a motion by Director Kennedy,
179 seconded by Director van Doorn, the motion to approve the Safety MOU Side Letter
180 regarding the Deputy Fire Marshal passed unanimously.

181 CS-4. CONFERENCE WITH LABOR NEGOTIATOR – GOVERNMENT CODE § 54957.6 – SAFETY
182 GROUP NEGOTIATIONS – CHIEF McREYNOLDS: No reportable action.

183 CS-5. EMPLOYMENT OF PUBLIC EMPLOYEE – GOVERNMENT CODE § 54957(b) – CHIEF
184 McREYNOLDS: On a motion by Director van Doorn, seconded by Director Kennedy, the
185 motion to approve the Executive Assistant/Board Clerk job description passed unanimously.
186 Recruitment to begin mid-July and anticipated start date of October 1, 2022.

187 CS-6. EMPLOYMENT OF PUBLIC EMPLOYEE – GOVERNMENT CODE § 54957(b) – CHIEF
188 McREYNOLDS: No reportable action.

ADJOURNMENT

191 At 6:35 p.m., a motion was made by Director Munson and seconded by Director van Doorn
192 to adjourn the meeting and reconvene on May 24, 2022, at 4:00 p.m., which motion carried
193 unanimously.

194 Respectfully submitted,

195 
196 Loren Stephen-Porter

197 Loren Stephen-Porter

198 Board Secretary

199 Minutes approved at the Board of Director's Meeting on: May 24, 2022

PAGE INTENTIONALLY BLANK



**NORTH COUNTY FIRE
PROTECTION DISTRICT
ADMINISTRATION - BUDGET & FINANCE**

TO: BOARD OF DIRECTORS
FROM: FIM CHERIE JUUL AND CHIEF McREYNOLDS
DATE: MAY 24, 2022
SUBJECT: REVENUE & EXPENDITURES AS OF APRIL 30, 2022 (83%)

Revenue Sources	Budgeted	Collected	Over/Under	% of Budget
Property Taxes - FBK	17,069,982.00	15,935,536.00	(1,134,446.00)	93%
Property Taxes - RNBW	344,250.00	345,171.00	921.00	100%
Ambulance and Collections	3,100,000.00	2,212,573.00	(887,427.00)	71%
GEMT-State Supplement	-	-	-	0%
Prevention Fees	250,000.00	204,456.00	(45,544.00)	82%
Tower Lease Agreements	91,045.00	75,724.00	(15,321.00)	83%
Other Revenue Sources	40,000.00	53,831.00	13,831.00	135%
Interest	50,000.00	24,408.00	(25,592.00)	49%
Cost Recovery	50,000.00	56,128.00	6,128.00	112%
Inspection Fee (Fire Prevention)	-	50,499.00	50,499.00	0%
Fallbrook Healthcare District	93,000.00	73,017.00	(19,983.00)	79%
Community Facilities District (CFD)	165,682.00	-	(165,682.00)	0%
Strike Team Reimbursements	198,126.00	761,698.00	563,572.00	384%
Other Reimbursements	40,782.00	195,021.00	154,239.00	478%
Mitigation Fees & Interest - FBK	310,000.00	509,625.00	199,625.00	164%
Donations & Grants	1,050,000.00	79,639.00	(970,361.00)	8%
Annexation fees (Meadowood)	-	165,149.00	165,149.00	
Transfers & Loans	259,000.00	-	(259,000.00)	
Total Revenue:	23,111,867.00	20,742,475.00	(2,369,392.00)	90%
	Budgeted	Spent	Over/Under	% of Budget
TTL Expenditures YTD thru 03-31-2022	23,111,867.00	15,558,680.00	(7,553,187.00)	67%
Revenue over Expenditures		5,183,795.00		

North County Fire Protection District
For the Tenth Month Ending April 30, 2022
83% of Budget

COLOR KEY	
Within/Below Budget	
Within 10% of Budget	
>10% of Budget (see notes)	

Description	April actual	Running Total	Final Budget	Amount Remaining	% Used	Notes
TOTAL PERSONNEL	991,600.00	12,818,196.00	15,983,173.00	3,164,977.00	80.2%	
101 Total Board Administration	173,086.00	328,835.00	516,000.00	187,165.00	63.7%	
102 Total Administration	59,736.00	624,913.00	1,090,162.00	465,249.00	57.3%	
103 Community Risk Reduction		13,904.00	72,400.00	58,496.00	19.2%	
104 Total Emergency Services	3,872.00	454,979.00	576,155.00	121,176.00	79.0%	
105 Total Emergency Med Svcs	52,558.00	478,658.00	528,385.00	49,727.00	90.6%	Applied GEMT overpayments to QAF
106 Total Volunteers/Explorers	-	-	2,000.00	2,000.00	0.0%	
107 Total Communications	114,274.00	524,639.00	665,800.00	141,161.00	78.8%	
108 Total Shop/Maintenance	25,855.00	248,068.00	398,580.00	150,512.00	62.2%	
109 Total Training	721.00	66,487.00	78,000.00	11,513.00	85.2%	Professional development/Training materials
120 Total General Fund Reserve	-	-	300,000.00	300,000.00	0.0%	
GRAND TOTAL	1,421,702.00	15,558,679.00	20,210,655.00	4,651,976.00	77.0%	
200 Total Capital Expenditures	7,145.89	979,943.72	1,400,239.00	420,295.28	70.0%	Admin bldg

**NORTH COUNTY FIRE PROTECTION DISTRICT
Tax Apportionments FY 21-22**

DATE	APP #	GROSS	REFUNDS & ADJUSTMENTS	FY 21/22 NET	FY 21/22 RUNNING	FY 20/21 NET	FY 20/21 RUNNING
08 10 2021	1	174,310.20	598.25	173,711.95	173,711.95	222,195.07	222,195.07
09 7 2021	2	119,254.23	1,950.18	117,304.05	291,016.00	205,194.77	427,389.84
10 12 2021	3	172,392.24	12,484.86	159,907.38	450,923.38	318,829.33	746,219.17
11 16 2021	4	914,192.18	18,143.61	896,048.57	1,346,971.95	923,408.43	1,669,627.60
12 14 2021	5	5,291,335.03	13,296.84	5,278,038.19	6,625,010.14	4,980,841.25	6,650,468.85
01 18 2022	6	2,793,673.33	14,774.32	2,778,899.01	9,403,909.15	2,313,908.54	8,964,377.39
02 15 2022	7	703,935.76	7252.73	696,683.03	10,100,592.18	595,281.17	9,559,658.56
03 22 2022	8	489,644.80	7,590.16	482,054.64	10,582,646.82	499,026.05	10,058,684.61
04 19 2022	9	5,276,798.06	164,377.30	5,112,420.76	15,695,067.58	3,611,048.63	13,669,733.24
05 24 2022	10				15,695,067.58	2,047,434.03	15,717,167.27
06 21 2022	11				15,695,067.58	413,139.25	16,130,306.52
07 21 2022	12				15,695,067.58	-	16,130,306.52
TOTAL YTD		15,935,535.83	240,468.25	15,695,067.58	15,695,067.58	13,669,733.24	13,669,733.24
Net Rev Increase							14.82%

RAINBOW FIRE PROTECTION SUBZONE

Tax Apportionments FY 21/22

DATE	APP #	GROSS	REFUNDS & ADJUSTMENTS	FY 21/22 NET	FY 21/22 RUNNING	FY 20/21 NET	FY 20/21 RUNNING
08 10 2021	1	3,497.61	12.00	3,485.61	3,485.61	4,276.12	4,276.12
09 7 2021	2	2,392.81	39.12	2,353.69	5,839.30	3,949.00	8,225.12
10 12 2021	3	3,459.07	3,208.61	250.46	6,089.76	6,135.86	14,360.98
11 16 2021	4	18,343.18	272.92	18,070.26	24,160.02	17,765.40	32,126.38
12 14 2021	5	116,485.83	275.57	116,210.26	140,370.28	96,384.50	128,510.88
01 18 2022	6	61,164.57	299.44	60,865.13	201,235.41	52,651.84	181,162.72
02 15 2022	7	15,186.77	149.29	15,037.48	216,272.89	11,942.49	193,105.21
03 22 2022	8	10,565.34	155.23	10,410.11	226,683.00	10,020.78	203,125.99
04 19 2022	9	114,075.65	3,558.24	110,517.41	337,200.41	72,758.15	275,884.14
05 24 2022	10			-	337,200.41	42,081.22	317,965.36
06 21 2022	11			-	337,200.41	8,274.78	326,240.14
07 21 2022	12			-	337,200.41	-	326,240.14
TOTAL YTD		345,170.83	7,970.42	337,200.41	337,200.41	203,125.99	203,125.99
Net Rev Increase							66.01%

**NORTH COUNTY FIRE PROTECTION DISTRICT
AMBULANCE REVENUE FY 2021-2022**

<u>MONTH</u>	<u>BILLED</u>	<u>CONTRACTUAL WRITE DOWNS</u>	<u>TOTAL AR FY 21-22</u>	<u>TOTAL AR FY 20-21</u>	<u>BAD DEBT WRITE-OFFS</u>	<u>REFUNDS</u>	<u>ADJ AR</u>	<u>DEPOSITS RECIEVED</u>	<u>BILLING FEES</u>	<u>FY 21-22 NET REVENUE</u>	<u>FY 20-21 NET REVENUE</u>	
07 31 2021	768,469.31	450,887.72	317,581.59	208,837.15	50,340.33	-	267,241.26	216,594.40	12,779.07	203,815.33	187,495.41	
08 31 2021	819,196.26	503,584.41	315,611.85	240,215.56	30,342.89	1,595.49	283,673.47	214,999.52	12,529.27	202,470.25	183,435.96	
09 30 2021	745,548.72	487,951.80	257,596.92	190,086.21	31,179.24	-	226,417.68	247,081.67	14,574.87	232,506.80	186,043.01	
10 31 2021	779,256.83	514,347.47	264,909.36	261,847.71	28,486.46	9,628.89	226,794.01	188,257.22	10,511.50	177,745.72	153,516.55	
11 30 2021	865,875.19	531,055.19	334,820.00	286,173.55	44,638.04	-	290,181.96	227,504.18	13,392.00	214,112.18	166,120.94	
12 31 2021	897,816.54	614,263.06	283,553.48	277,727.18	78,658.44	5,633.82	199,261.22	225,617.52	12,979.04	212,638.48	192,206.10	
01 31 2022	859,215.83	575,356.71	283,859.12	302,698.66	38,450.12	11,181.51	234,227.49	197,281.80	10,971.69	186,310.11	177,888.16	
02 28 2022	826,637.61	509,482.44	317,155.17	283,155.22	44,977.12	5,144.34	267,033.71	285,215.93	16,509.47	268,706.46	173,005.15	
03 31 2022	868,836.18	575,464.71	293,371.47	253,438.15	21,317.41	-	272,054.06	253,163.93	14,819.18	238,344.75	229,301.16	
04 30 2022	825,638.77	483,020.42	342,618.35	280,600.28	26,833.50	5,161.21	310,623.64	215,689.62	12,301.43	203,388.19	175,697.29	
05 31 2022			-	252,666.36			-			-	245,289.37	
06 30 2022			-	255,358.64			-			-	184,886.61	
TOTAL:	8,256,491.24	5,245,413.93	3,011,077.31	2,584,779.67	395,223.55	38,345.26	2,577,508.50	2,271,405.79	131,367.52	2,140,038.27	1,824,709.73	
					Net A/R Change		16.49%			New Revenue Change		17.28%

<p>NORTH COUNTY FIRE PROTECTION DISTRICT</p> <p>MONTHLY INVESTMENT REPORT</p>

April 30, 2022

FALLBROOK	BALANCE	INTEREST	
		RATE	
County of San Diego/General Fund - FBK	6,751,760.61	0.01%	Operating
County of San Diego/General Fund - RNBW	1,857,284.63	0.01%	Operating
County of San Diego/Capital Reserve	405,631.24	0.01%	Capital Reserves
County of San Diego/Fire Mitigation Fund - FBK	1,365,321.35	0.01%	Mitigation Fees
County of San Diego/Fire Mitigation Fund - RNBW	4,109.33	0.01%	Mitigation Fees
Local Agency Investment Fund	4,164,275.90	0.28%	LAIF
Workers' Comp JPA	489,484.42	0.17%	PASIS Funds
Bank of America/PASIS	83,425.17	0.01%	
First National/Benefit Fund	157,301.61	0.35%	
First National/Payroll	312,380.73	0.35%	
First National/Accounts Payable	139,000.72	0.35%	
First National/Accounts Receivable	1,072,656.54	0.35%	
Pacific Western Bank/Accounts Receivable	2,691,024.46	0.00%	
TOTAL	19,493,656.71		

**NORTH COUNTY FIRE PROTECTION DISTRICT
COST RECOVERY FY 2021/2022**

<u>Month</u>	<u>Billed</u>	<u>Collected</u>	<u>YTD % Collected</u>	<u>Billing Fees</u>	<u>Net Revenue 21/22</u>	<u>Net Revenue 20/21</u>
7 31 2021	5,677.00	5,424.18	95.55%	1,084.84	4,339.34	5,308.83
8 30 2021	11,521.50	8,038.54	69.77%	1,607.71	6,430.83	2,673.60
9 30 2021	6,122.50	5,215.45	85.18%	1,043.09	4,172.36	2,066.66
10 31 2021	8,239.75	7,988.75	96.95%	1,597.75	6,391.00	2,502.00
11 30 2021	2,885.50	2,450.00	84.91%	490.00	1,960.00	2,731.12
12 31 2021	9,190.75	8,959.75	97.49%	1,791.95	7,167.80	2,823.05
1 31 2022	8,018.50	5,720.10	71.34%	1,144.02	4,576.08	6,741.66
2 28 2022	6,746.50	6,436.21	95.40%	1,287.24	5,148.97	2,473.00
3 30 2022	41,052.00	10,623.77	25.88%	2,124.75	8,499.02	5,971.02
4 30 2022	8,064.92	9,303.72	115.36%	1,860.74	7,442.98	3,468.99
5 31 2022			#DIV/0!	-	-	5,093.99
6 30 2022			#DIV/0!	-	-	5,826.80
TOTAL:	107,518.92	70,160.47	65.25%	14,032.09	56,128.38	36,759.94
					Net Rev Increase	52.69%

therecoveryhub.com
Ncfdp1105 Chrome
Claims>reports

Document Date	Document Number	Vendor Name	Transaction Description	Document Amount
04 1 2022	0381472030222	TIME WARNER CABLE	3/2/22-4/1/22	1,296.67
04 1 2022	0381456030222	TIME WARNER CABLE	3/2/22-4/1/22	346.67
04 1 2022	04/2022	THE STANDARD	april life insurance	580.00
04 1 2022	04/2022	Employee Benefit Specialists, Inc.	dental vision april 2022	9,388.75
04 1 2022	04/2022	Harry J. Wilson Insurance Center	april 2022	1,143.00
04 1 2022	JAN-MARCH 2022	CELESTINO CHAVEZ	CELL REIMBURSEMENT	102.00
04 1 2022	03/2022	ROBERT JAMES	march 2022 stmt	4,107.50
04 1 2022	03/4/22-04/01/22 ST	FALLBROOK PUBLIC UTILITY DISTR	st 2 wter 3/4/4/1	301.01
04 1 2022	03/4/2-04/1/22 ADMIN	FALLBROOK PUBLIC UTILITY DISTR	admin water/sewer march 22	460.14
04 1 2022	4132-02	ERICKSON-HALL CONSTRUCTION	PRECONSTRUCT SERVICES	1,365.00
04 1 2022	03/2022 180000298	INTERSTATE BATTERY OF SD	march 2022 stmt	377.11
04 1 2022	9903055415	VERIZON WIRELESS	3/2/22-4/1/22	77.24
04 1 2022	04P14052	San Diego Friction Products, Inc.	BENDIX AIR CK VLV	70.31
04 1 2022	015910964	XEROX - PASADENA	XEROX UPSTAIRS	426.95
04 1 2022	015910963	XEROX - PASADENA	XEROX DOWNSTAIRS	150.04
04 4 2022	SHOES 2022 2	RICHARD BERRY	workout shoes	35.00
04 4 2022	1068653	KENETREK BOOTS	WILDLAND FIRE BOOT	246.98
04 5 2022	2215618-0	GLENNIE'S OFFICE PRODUCTS	MULTIPURPOSE COPY PAPER	96.95
04 5 2022	2215620-0	GLENNIE'S OFFICE PRODUCTS	PAPER PAD LEGAL JR	59.20
04 5 2022	407 - 2	RIDEOUT ELECTRIC	ST. 2 ELECTRIC	437.45
04 6 2022	000017817329	AT&T	stmt	148.68
04 6 2022	0000240032022 2	TIME WARNER CABLE	st 1 internet	149.95
04 6 2022	41129	LineGear	harrington FF wildland boot	315.62
04 7 2022	000017840329	AT&T	2/1/22-2/28/22	1,939.40
04 7 2022	1281	FIRST ALARM WELLNESS	02/2022 stmt	1,931.25
04 8 2022	PR 04/08/22	LINCOLN NATIONAL	03/13/22-03/26/22	3,906.61
04 8 2022	PR 04/08/22	FIREFIGHTERS LEG. ACTION GRP	03/13/22-03/26/22	450.00
04 8 2022	SR PR 04/08/22	FALLBROOK FIREFIGHTERS' ASSN	03/13/22-03/26/22	30.42
04 8 2022	PR 04/08/22	FALLBROOK FIREFIGHTERS' ASSN	03/13/22-03/26/22	2,678.14
04 8 2022	4132-02 II	ERICKSON-HALL CONSTRUCTION	PRECONSTRUCT SERVICES	10,257.50
04 8 2022	263311	Fowler Pest Control	bi monthly april 2022 pest	90.00
04 9 2022	4041-2	RAWLINGS ELECTRIC, INC	tem generator installation	3,450.00
04 10 2022	0417565031122	TIME WARNER CABLE	03/11/22-04/10/22	107.98
04 10 2022	ST 1 4/10/22	FALLBROOK PUBLIC UTILITY DISTR	st 1 water	130.06
04 10 2022	3/23/22 ST 1	FALLBROOK PUBLIC UTILITY DISTR	st 1 water sewere	533.53
04 10 2022	FY 22-23	SAN DIEGO COUNTY VECTOR CONTROL PROGRAM	vector assessment st 1 + 4	66.96
04 11 2022	2203099	Wittman Enterprises, LLC	march 2022	14,819.18
04 11 2022	0417565041122	TIME WARNER CABLE	4/11/22-05/10/22	107.98
04 11 2022	EI01308340	EIDE BAILLY	march 2022 eide bailly	6,445.98
04 13 2022	CFO 3D	NICK CRILLY	chief fire officer 3d	440.00
04 14 2022	LAST DAY):	AARON MURG	AARONS LUNCHEON LAST DAY	165.94
04 14 2022	287294515164X0421202	AT&T	att 3/14-4/14/22	1,729.00
04 15 2022	JAN-MARCH 2022	KEVIN MAHR	CELL REIMB	300.00

Document Date	Document Number	Vendor Name	Transaction Description	Document Amount
04 15 2022	266461-267520	NAPA AUTO PARTS	march 2022 stmt	1,050.24
04 15 2022	04/2022 1	FALLBROOK OIL COMPANY	april 2022 stmt 1	5,937.27
04 16 2022	1285 2	FIRST ALARM WELLNESS	q2 2021	2,087.50
04 16 2022	1286 2	FIRST ALARM WELLNESS	july 2021	550.00
04 16 2022	1287 2	FIRST ALARM WELLNESS	aug 2021	462.50
04 16 2022	1288 2	FIRST ALARM WELLNESS	sep 2021	625.00
04 16 2022	1289 2	FIRST ALARM WELLNESS	oct 2021	750.00
04 16 2022	1290 2	FIRST ALARM WELLNESS	nov 2021	1,631.25
04 16 2022	1291 2	FIRST ALARM WELLNESS	dec 2021	2,000.00
04 17 2022	139736 2	CDCE Engineered Solutions	multi band antenna	905.10
04 20 2022	062997645X220322 2	DIRECTV	3/21/22-4/20/22	177.98
04 20 2022	IN47629708	CROP PRODUCTION SERVICES	march stmt 2022	91.27
04 20 2022	2022 PM CARD	JOSEPH BRADSHAW	PM recert	250.00
04 21 2022	SEWER 4/21/22	RAINBOW MUNICIPAL WATER DIST	sewer only	54.40
04 21 2022	3/24/22 ST 4	RAINBOW MUNICIPAL WATER DIST	sewer + water st 4	208.68
04 21 2022	9164	FIRE AND SAFETY CONSULTING LLC	low beam rht + shipping	215.24
04 21 2022	ST 2 LOCKERS	MAURICIO VARELA	st 2 lockers 11.5 ft	7,245.00
04 21 2022	BUS 4000	Collin Baker	baker bus 4000 waldorf	837.00
04 21 2022	051022 ST 1	FALLBROOK PUBLIC UTILITY DISTR	3/24/22-04/21/22	65.03
04 21 2022	WATER SEWER ST 1	FALLBROOK PUBLIC UTILITY DISTR	water/sewer st 1	568.21
04 22 2022	RFP MARCH 2022	Reeder Media	requests for proposals notice	300.00
04 22 2022	PR AP 04/22/22	LINCOLN NATIONAL	03/27/22-04/09/22	3,386.05
04 22 2022	PR AP 04/22/22	FIREFIGHTERS LEG. ACTION GRP	03/27/22-04/09/22	450.00
04 22 2022	SR PR 04/22/22	FALLBROOK FIREFIGHTERS' ASSN	03/27/22-04/09/22	25.74
04 22 2022	PR 04/22/22	FALLBROOK FIREFIGHTERS' ASSN	03/27/22-04/09/22	2,678.14
04 24 2022	FSC 4510	Erik Alter-Reitz	FSC 4510	837.00
04 24 2022	04/2022	LEGAL SHIELD	legal shield april 2022	458.60
04 25 2022	ST 1 3/31	SUNSHINE WATER SOFTENERS & MORE	st 1 water	35.00
04 25 2022	ST 2 3/31	SUNSHINE WATER SOFTENERS & MORE	st 2 sunshine 3/31	35.00
04 25 2022	ST 3 3/31	SUNSHINE WATER SOFTENERS & MORE	st 3	35.00
04 25 2022	ST 5 03/31	SUNSHINE WATER SOFTENERS & MORE	st 5 3/31	35.00
04 25 2022	ST 4 03/31	SUNSHINE WATER SOFTENERS & MORE	st 4	35.00
04 25 2022	PM RENEWAL 2022	BRENT ITZAINA	pm renewal 2022	250.00
04 25 2022	RFP 2022	Reeder Media	PUBLIC NOTICE RFP	200.00
04 26 2022	FSC 4510	NICK CRILLY	crilly fsc 4510	837.00
04 27 2022	202122-146	NORTH COUNTY DISPATCH JPA	dispatch fee FY 21/22 q3	106,088.37
04 28 2022	S-270	NICK CRILLY	s-270 basic air operations	200.00
04 28 2022	PA 5306	MATHIEU LINDSEY	pa 5306 waldorf	1,107.00
04 28 2022	TAXES Q1 2022	UNITED STATES TREASURY	quarterly tax return	65.01
04 29 2022	500426949	DEL CITY	MARINE RATED 50 AMP	153.25
04 30 2022	IN1695726	MES California	helmet/headlights angle lights	1,244.10

PAGE INTENTIONALLY BLANK



**NORTH COUNTY FIRE
PROTECTION DISTRICT
FIRE CHIEF/CEO**

TO: BOARD OF DIRECTORS
FROM: KEITH MCREYNOLDS, FIRE CHIEF/CEO
DATE: MAY 24, 2022
SUBJECT: APPROVAL OF POLICIES AND PROCEDURES

The following Policies and Procedures are being presented for review and approval:

1. Employee Physical Exams - Rules & Regulations – Conditions of Employment:
 - Revision to reflect current practice and vendor.
2. Physical Ability Examination - Rules & Regulations – Conditions of Employment:
 - Policy updated to meet current practice for return to work.



NORTH COUNTY FIRE PROTECTION DISTRICT

POLICY AND PROCEDURE MANUAL

ADMINISTRATION
RULES & REGULATIONS
CONDITIONS OF EMPLOYMENT

SECTION 223.21
SEPTEMBER 22, 2015
PAGE 1 OF 5

EMPLOYEE PHYSICAL EXAMS

1.0. PURPOSE:

- 1.1. The purpose of this Policy is to provide guidelines pertaining to the physical fitness evaluations for District employees. Refer to the Worker's Compensation Policy for information pertaining to Qualified Medical Evaluator (QME) examinations.

2.0. POLICY:

~~2.1.~~ It is the Policy of the North County Fire Protection District ("~~District~~") to provide a ~~comprehensive baseline~~ occupational medical exams for ~~all new~~ District employees ~~on an annual basis~~, after a conditional offer of employment and to provide annual periodic occupational medical evaluations for current employees as described herein.

~~2.2.2.1.~~ District Suppression employees are required to undergo an annual ~~periodic~~ occupational medical evaluation (physical exam) by a qualified, licensed medical professional as described herein, in order to comply with Respiratory Protection (8 CCR § 5144) and California Driver's license maintenance requirements (CVC 12804.11), which are conditions of continued employment. Occupational medical evaluations are voluntary for administrative ~~non-safety~~ personnel and are provided by the District.[NG1]

~~2.3.~~ All District employees may be subject to a fitness for duty medical evaluation as determined by ~~the~~ Human Resources ~~Officer~~ or their designee, as described herein. ~~Employees furnishing a physician's return to work statement may not be subjected to a fitness for duty evaluation unless the employee's post behavior leave justifies such.~~

~~2.4.2.2.~~ District employees who are returning to work from a significant injury or illness (incurred either on or off duty) may be subject to a return to duty evaluation by the District's medical provider. The District may approve a return to work statement from the employee's personal physician for off-duty injuries or request that the employee complete a Fit-for-Duty examination by the District's medical provider. For purposes of this policy a "significant" injury or illness includes but is not limited to one that results in a loss of time that is covered by the Family Medical Leave Act, California Family Rights Act, Pregnancy Disability Leave, exhaustion of Sick Leave, "light Duty," "4850 time" or exceeds thirty (30) days in length.

~~2.5.2.3.~~ Medical evaluations for Suppression personnel shall be based upon NFPA 1582.



NORTH COUNTY FIRE PROTECTION DISTRICT

POLICY AND PROCEDURE MANUAL

ADMINISTRATION
RULES & REGULATIONS
CONDITIONS OF EMPLOYMENT

SECTION 223.21
SEPTEMBER 22, 2015
PAGE 2 OF 5

EMPLOYEE PHYSICAL EXAMS

3.0. INTENT:

3.1. The intent of this Policy is to maintain a safe, healthy, injury-free workforce by incorporating a variety of health promotion, wellness and physical examination methodologies based upon contemporary industry best practices.

4.0. PROCEDURE:

~~4.1. BASELINE MEDICAL EXAM: A baseline medical exam will be conducted by a qualified, licensed medical professional of the District's choosing for all persons who have received a conditional offer of employment. This exam is based upon the prospective employee's classification and will consist of the following:~~

~~4.1.1. OFFICE/CLERICAL SUPPORT PERSONNEL:~~

- ~~4.1.1.1. Review of medical & occupational history;~~
- ~~4.1.1.2. Core physical examination, consisting of:
 - ~~• Vital signs;~~
 - ~~• Head, ears, eyes, nose, and throat;~~
 - ~~• Thyroid gland, inspection and palpation;~~
 - ~~• Cardiovascular: inspection, auscultation, percussion and palpation;~~
 - ~~• Pulmonary: inspection, auscultation, percussion and palpation;~~
 - ~~• Gastrointestinal: inspection, auscultation, percussion and palpation;~~
 - ~~• Hernia exam (males);~~
 - ~~• Lymph nodes: cervical and axillary;~~
 - ~~• Neurological exam and assessment of major cranial/peripheral nerves, motor, sensory, and reflexes;~~
 - ~~• Musculoskeletal: overall assessment of range of motion of all joints.~~~~
- ~~4.1.1.3. Pulmonary Function Test (Spirometry);~~
- ~~4.1.1.4. Audiogram;~~
- ~~4.1.1.5. Vision Testing (Examination plus Titmus). Includes distance, near, peripheral and color vision;~~
- ~~4.1.1.6. Chest x-ray (PA and Lateral);~~
- ~~4.1.1.7. Resting ECG;~~
- ~~4.1.1.8. Complete blood count (CBC);~~
- ~~4.1.1.9. Comprehensive Metabolic Panel (CMP);~~
- ~~4.1.1.10. Lipid Profile;~~
- ~~4.1.1.11. Prostate Specific Antigen (PSA-males >40);~~
- ~~4.1.1.12. Digital Rectal Exam (DRE-males >50);~~
- ~~4.1.1.13. Breast exam (women);~~



NORTH COUNTY FIRE PROTECTION DISTRICT

POLICY AND PROCEDURE MANUAL

ADMINISTRATION
RULES & REGULATIONS
CONDITIONS OF EMPLOYMENT

SECTION 223.21
SEPTEMBER 22, 2015
PAGE 3 OF 5

EMPLOYEE PHYSICAL EXAMS

~~4.1.1.14. Urinalysis (microscopic), includes WBC, RBC, WBC casts, RBC casts and crystals;~~

~~4.1.1.15. Collection of urine specimen for drug/alcohol screen for new hires;~~

~~4.1.1.16. Immunizations and Infectious Disease Screening: Immunization history to be obtained, with required immunizations to be provided with individual's approval and signed consent. Blood tests to document laboratory immunity and immunizations provided at an additional cost:~~

- ~~• Hepatitis C titer;~~
- ~~• Hepatitis B titer, if no documentation[NG2] available;~~
- ~~• Varicella titer, if no documentation;~~
- ~~• HIV screening (offered on a confidential basis if permitted by patient);~~
- ~~• TDAP, if no documentation available;~~
- ~~• MMR, if no documentation available;~~
- ~~• Tuberculosis (Mantoux TST or QFT Gold for false positive TST persons).~~

~~4.1.2. **SUPPRESSION PERSONNEL:** In addition to the preceding, the Baseline Medical Evaluation for Suppression Personnel shall also include:~~

~~4.1.2.1. Respirator Use Medical Clearance;~~

~~4.1.2.2. DMV Class C Driver's License w/ Firefighter Endorsement Medical Clearance;~~

~~4.1.2.3. Fitness evaluation consisting of:~~

- ~~• Body composition assessment with skin fold measures;~~
- ~~• Aerobic capacity utilizing the Bruce Protocol Stress Test;~~
- ~~• Push ups;~~
- ~~• Sit-ups;~~
- ~~• Leg strength or vertical jump;~~
- ~~• Arm strength;~~
- ~~• Grip strength;~~
- ~~• Flexibility evaluation.[BM3]~~

~~4.2.2.1. **ANNUAL PERIODIC OCCUPATIONAL MEDICAL EVALUATION:** The annual ~~periodic~~ occupational medical evaluation consists of two parts, a wellness and fitness evaluation (WEFIT) and a medical physical exam. ~~Details for the various components listed herein are enumerated under the Baseline Medical Exam.~~[KM4]~~



NORTH COUNTY FIRE PROTECTION DISTRICT

POLICY AND PROCEDURE MANUAL

ADMINISTRATION
RULES & REGULATIONS
CONDITIONS OF EMPLOYMENT

SECTION 223.21
SEPTEMBER 22, 2015
PAGE 4 OF 5

EMPLOYEE PHYSICAL EXAMS

4.2.1. **WELLNESS AND FITNESS EVALUATION:** The WEFIT program ~~is currently administered by Santa Ana College and~~ consists of a battery of non-diagnostic physical and laboratory evaluations. ~~Participation in this program is voluntary however test results are forwarded to the District's physician as background information for the occupational medical evaluation.~~ Findings of the WEFIT evaluation are kept confidential. ~~The WEFIT evaluation consists of:~~

- ~~• Blood analysis (CBC, CMP, Lipid profile & PSA for males > 40 yrs. old);~~
- ~~• Urinalysis;~~
- ~~• Spirogram;~~
- ~~• Resting and/or Stress ECG;~~
- ~~• Fitness evaluation;~~
- ~~• Individualized Health Risk Appraisal — provided to employee upon completion.~~

4.2.2. **OCCUPATIONAL MEDICAL EVALUATION:** The occupational medical evaluation is conducted annually ~~periodically~~ by a licensed medical practitioner designated by the District to evaluate employees' overall health and fitness to ensure they can continue to perform their jobs safely and free from injury. ~~This evaluation consists of:~~

- ~~• Review of occupational and medical history;~~
- ~~• Review of WEFIT evaluation results and Respiratory Protection Questionnaire;~~
- ~~• Core physical examination;~~
- ~~• Audiogram;~~
- ~~• Vision Test;~~
- ~~• Chest x-ray (every 5 years or as indicated);~~
- ~~• Cancer screening (DRE or Breast exam);~~
- ~~• Tuberculosis test (TST or QFT for false positives);~~
- ~~• Completion of DMV 546A (every 4 years).~~

4.3. **FITNESS FOR DUTY EVALUATION:** Where the District has concerns that can involve occupational and environmental health issues, or if there are concerns over an employee's ability to safely perform their job, an occupational medical ~~medicine~~ ^{consult} may be requested. This evaluation will include:

- 4.3.1. Focused history and physical examination;
- 4.3.2. Review of relevant records;
- 4.3.3. Further diagnostic studies or consultation as indicated.



NORTH COUNTY FIRE PROTECTION DISTRICT

POLICY AND PROCEDURE MANUAL

ADMINISTRATION
RULES & REGULATIONS
CONDITIONS OF EMPLOYMENT

SECTION 223.21
SEPTEMBER 22, 2015
PAGE 5 OF 5

EMPLOYEE PHYSICAL EXAMS

- 4.4. RETURN TO WORK EVALUATION: Employees returning to work following non-worker's compensation related injuries/illnesses are to obtain a physician's return to work evaluation at their expense. Return to work evaluations will be provided by the District for work-related injuries/illnesses. In either case, the physician's return to work statement must clearly identify any work restrictions. The components of a return to work evaluation mirror the fitness for duty evaluation, plus completion of the District's standard Physical Ability Examination.



NORTH COUNTY FIRE PROTECTION DISTRICT

POLICY AND PROCEDURE MANUAL

ADMINISTRATION
RULES AND REGULATIONS
CONDITIONS OF EMPLOYMENT

SECTION 223.14

JUNE 12, 2007

PAGE 1 OF 17

PHYSICAL ABILITY EXAMINATION

1.0. PURPOSE:

- 1.1. To provide a standard for the evaluation of suppression personnel to ensure an acceptable degree of physical ability to meet the Mission ~~needs~~ of the District.

2.0. POLICY:

- 2.1. By virtue of employment with North County Fire Protection District, all safety personnel are subject to physical standards necessary to carry out required suppression duties.

3.0. INTENT:

- 3.1. The District shall strive to ensure that all suppression personnel are physically capable to perform their job of firefighting.

4.0. DEFINITION:

- 4.1. All safety personnel will be required to participate and pass an ~~annual~~ physical ability assessment in order to continue in suppression activities after a "significant" injury or illness including but not limited to one that results in a loss of time that is covered by Family Medical Leave, Pregnancy Disability Leave, exhaustion of Sick Leave, "light Duty," "4850 time", exceeds thirty (30) days in length.

5.0. SCOPE:

- 5.1. This policy shall apply to all career personnel that may be assigned to duty responsibility.

6.0. PROCEDURE:

6.1. PHYSICAL ABILITY EXAMINATION:

- 6.1.1. All ~~full time~~ full-time career ~~engine-company~~ safety personnel shall successfully perform the ~~annual~~ physical ability examination when returning from an injury or illness. ~~This requirement shall also apply to personnel assigned to other Divisions who may, "will call" in Fire Suppression Operations.~~ All individuals who are unable to successfully complete the physical ability examination shall adhere to the guidelines as set forth in this document. ~~The Training Division Chief or their designee shall administer the Physical Ability Examination three~~



NORTH COUNTY FIRE PROTECTION DISTRICT

POLICY AND PROCEDURE MANUAL

ADMINISTRATION
RULES AND REGULATIONS
CONDITIONS OF EMPLOYMENT

SECTION 223.14

JUNE 12, 2007

PAGE 2 OF 17

PHYSICAL ABILITY EXAMINATION

~~times per month, if needed, in the second quarter of the year (April, May, June). Additional Examinations may be on a monthly basis as needed. All documentation shall be maintained in the employee's personnel file.~~

- 6.1.2. If an individual fails to take or successfully complete the examination due to medical reasons, they will be placed on the appropriate duty status leave (Sick Leave, Industrial Injury Leave) until able to take the examination.
- 6.1.3. The Physical Ability Examination is based upon performance of job skills as defined within the job classifications. Therefore, the following maximum times shall be applied per job classification:
 - 6.1.3.1. Firefighter and Firefighter/Paramedic, 6 minutes 15 seconds;
 - 6.1.3.2. Engineer and Engineer/Paramedic, 6 minutes 30 seconds;
 - 6.1.3.3. Captain and Captain/Paramedic, 6 minutes 45 seconds; and
 - 6.1.3.4. Chief Officers with duty responsibilities, 7 minutes.
- 6.1.4. The wildland safety uniform shall be worn during all Physical Ability Examinations and practice events.
- 6.1.5. Prior to commencing with the Physical Ability Examination, personnel shall complete a two-minute warm up and stretching period.
- 6.2. The following guidelines will be utilized for employees who are unable to successfully complete the physical ability examination:

~~6.2.1. FAILS PHYSICAL ABILITY EXAMINATION FIRST TIME:~~

- ~~6.2.1.1. Employee shall receive a verbal notice of correction by their supervisor.~~
- ~~6.2.1.2. Employee shall remain on full duty status.~~
- ~~6.2.1.3. Employee shall retake the examination within 30 days.~~
- ~~6.2.1.4. Employee may elect to retake the examination the same day after a rest period and time permitting.~~
- ~~6.2.1.5. 6.2.1.1. The Physical Abilities Examination results form, which documents completion or failure, shall be placed in the employee's personnel file.~~

~~6.2.2. FAILS PHYSICAL ABILITY EXAMINATION SECOND TIME:~~

- ~~6.2.2.1. Notice of Improvement needed shall be completed by the employee's supervisor.~~



NORTH COUNTY FIRE PROTECTION DISTRICT

POLICY AND PROCEDURE MANUAL

ADMINISTRATION
RULES AND REGULATIONS
CONDITIONS OF EMPLOYMENT

SECTION 223.14
JUNE 12, 2007
PAGE 3 OF 17

PHYSICAL ABILITY EXAMINATION

- ~~6.2.2.2. Individual Development Plan For Employees shall be filled out by the employee's immediate supervisor.~~
- ~~6.2.2.3. The District shall schedule an appointment for the employee with the District's Physical Therapist for evaluation and recommended corrective action.~~
- ~~6.2.2.4. Employee shall remain on full duty status.~~
- ~~6.2.2.5. Employee shall retake the examination within 60 days but no sooner than 45 days.~~
- ~~6.2.2.6. Employee may not retake the examination the same day as the second failure.~~
- ~~6.2.2.7. The Physical Abilities Examination results form, which documents completion or failure, shall be placed in the employee's personnel file.~~

6.2.3. FAILS PHYSICAL ABILITY EXAMINATION THIRD TIME:

- ~~6.2.3.1. The employee will be placed on the appropriate duty status leave (Sick Leave, Industrial Injury Leave) until able to retake the examination. Notice of Unsatisfactory Work Performance shall be completed by the employee's supervisor in conference with the Duty Chief.~~
- ~~6.2.3.2. Individual Development Plan for Employees shall be completed by the employee's supervisor in conference with the Duty Chief.~~
- ~~6.2.3.3. Human Resources Officer shall be notified by Training Division and provided with all documentation.~~
- ~~6.2.3.4. Additional disciplinary action shall be enacted in accordance with District policies.~~
- ~~6.2.3.5. Employee shall be placed on Administrative Assignment (0730-1630 Monday — Friday) until they successfully pass the Physical Abilities Examination.~~
- ~~6.2.3.6.6.2.1.2. The District shall schedule an appointment for the employee with the District's Physician to obtain medical clearance prior to attempting the next Physical Abilities Examination.~~
- ~~6.2.3.7.6.2.1.3. Employee shall be re-evaluated by the employees Medical Physician (Off-Duty Injury) or the District's medical provider Physical Therapist for evaluation and recommended corrective action.~~
- ~~6.2.3.8.6.2.1.4. The Training Division will re-test the employee at the completion of the 30 days.~~
- ~~6.2.3.9.6.2.1.5. The Physical Abilities Examination results form, which documents completion or failure, shall be placed in the employee's filed by Human Resources. personnel file.~~



NORTH COUNTY FIRE PROTECTION DISTRICT

POLICY AND PROCEDURE MANUAL

ADMINISTRATION
RULES AND REGULATIONS
CONDITIONS OF EMPLOYMENT

SECTION 223.14

JUNE 12, 2007

PAGE 4 OF 17

PHYSICAL ABILITY EXAMINATION

6.2.4.6.2.2. FAILS PHYSICAL ABILITY EXAMINATION FOURTH TIME:

- ~~6.2.4.1. Notice of Unsatisfactory Work Performance shall be completed by the employee's supervisor in conference with the Duty Chief.~~
- ~~6.2.4.2.6.2.2.1. Individual Development Plan for Employees shall be completed by the employee's supervisor in conference with the Duty Chief.~~
- ~~6.2.4.3. Human Resources Officer shall be notified by Training Division and provided with all documentation.~~
- ~~6.2.4.4. Additional disciplinary action shall be enacted in accordance with District policies.~~
- ~~6.2.4.5. Employee will remain on Administrative Assignment.~~
- ~~6.2.4.6. Employee must obtain medical clearance from Districts physician prior to attempting next Physical Abilities Examination.~~
- ~~6.2.4.7. Employee shall be re-evaluated by District's Physical Therapist for evaluation and recommended corrective action.~~
- ~~6.2.4.8. The Training Division will re-test the employee at the completion of the 30 days.~~
- ~~6.2.4.9.6.2.2.2. The Physical Abilities Examination results form, which documents completion or failure, shall be placed in the employee's personnel file.~~

6.2.5.6.2.3. FAILS PHYSICAL ABILITY EXAMINATION FIFTH TIME:

- ~~6.2.5.1. Notice of Unsatisfactory Work Performance shall be completed by the employee's supervisor in conference with the Duty Chief.~~
- ~~6.2.5.2.6.2.3.1. Individual Development Plan for Employees shall be completed by the employee's supervisor in conference with the Duty Chief.~~
- ~~6.2.5.3. Human Resources Officer shall be notified by Training Division and provided with all documentation.~~
- ~~6.2.5.4. Suspension with out pay until employee passes Physical Ability Examination.~~
- ~~6.2.5.5. Employee must obtain medical clearance from Districts physician prior to attempting next Physical Abilities Examination.~~
- ~~6.2.5.6. Employee may schedule a re-examination through the Training Officer within 60 days but no sooner than 30 days.~~
- ~~6.2.5.7. If not successfully completed within 60 days, the Human Resources Officer shall recommend termination to the Fire Chief.~~
- ~~6.2.5.8.6.2.3.2. The Physical Abilities Examination results form, which documents completion or failure, shall be placed in the employee's personnel file.~~



NORTH COUNTY FIRE PROTECTION DISTRICT

POLICY AND PROCEDURE MANUAL

ADMINISTRATION
RULES AND REGULATIONS
CONDITIONS OF EMPLOYMENT

SECTION 223.14

JUNE 12, 2007

PAGE 5 OF 17

PHYSICAL ABILITY EXAMINATION

~~6.2.6. EMPLOYEE FAILS TO TAKE PHYSICAL ABILITIES EXAMINATION DURING SCHEDULED IN-SERVICE TRAINING OR MAKE-UP:~~

~~6.2.6.1. Employee shall submit an administrative action report to the Human Resources Officer explaining why they were unable to attend the Physical Abilities Examination within the time frame.~~

~~6.2.6.2. Employee may be subject to Administrative Assignment until successful completion.~~

~~6.2.7. EMPLOYEE REFUSES TO PARTICIPATE IN PHYSICAL ABILITY EXAMINATION:~~

~~6.2.7.1. Employee refuses a Direct Order to participate in Physical Ability Examination.~~

~~6.2.7.1.1. Immediate Supervisor will document and notify the Duty Chief. The Duty Chief in keeping with District policies will initiate disciplinary action.~~

~~6.2.7.1.2. Human Resources Officer will order employee to participate in physical ability test. Training Officer will schedule within approximately one week.~~

~~6.2.8. EMPLOYEE REFUSES SECOND DIRECT ORDER TO PARTICIPATE IN PHYSICAL ABILITY EXAMINATION:~~

~~6.2.8.1. Immediate Supervisor will document and notify the Duty Chief. The Duty Chief in keeping with District policies will initiate disciplinary action.~~

~~6.2.8.2. Human Resources Officer will order employee to participate in Physical Ability Examination. Training Officer will schedule within approximately one week.~~

~~6.2.9. EMPLOYEE REFUSES THIRD DIRECT ORDER TO PARTICIPATE IN PHYSICAL ABILITY EXAMINATION:~~

~~6.2.9.1. TERMINATION: Human Resources Officer recommends employee termination to the Fire Chief.~~

6.3. OFF-DUTY USE OF TRAINING AREA TO PREPARE FOR PHYSICAL ABILITIES EXAMINATION:

6.3.1. Employee must reserve time slot in advance through the Training Division.



NORTH COUNTY FIRE PROTECTION DISTRICT

POLICY AND PROCEDURE MANUAL

ADMINISTRATION
RULES AND REGULATIONS
CONDITIONS OF EMPLOYMENT

SECTION 223.14

JUNE 12, 2007

PAGE 6 OF 17

PHYSICAL ABILITY EXAMINATION

- 6.3.2. Use of the area and equipment is limited and shall not interfere with other District needs.
- 6.3.3. The wildland safety uniform with helmet shall be worn during the practice session.
- 6.3.4. A sufficient warm-up period in which stretching exercises are performed is mandatory prior to practicing any event.
- 6.3.5. After use, all equipment is to be stored in the same manner as prior to use.
- 6.4. PHYSICAL ABILITY EXAMINATION MAKE-UP:
 - 6.4.1. Personnel required to participate in the Physical Ability Examination who are absent due to extended leave (extended light duty, industrial injury leave, extended sick leave, long term disability, leave of absence etc.) shall upon return to duty perform the annual ability examination.
 - 6.4.1.1. Employee's supervisor shall schedule an examination through the Training Division within thirty (30) days.
 - 6.4.1.2. ~~If an individual successfully completes a Physical Ability Examination less than ninety (90) calendar days prior to the scheduled Annual Physical Ability Examination, such successful completion will count for that individual's annual Physical Ability Examination.~~
- 6.5. PHYSICAL ABILITIES EXAMINATION EVENT RULES:
 - 6.5.1. DRY HOSE DRAG:
 - 6.5.1.1. Employees' time starts when their foot hits the pavement.
 - 6.5.1.2. The Siamese must go beyond the 150' line.
 - 6.5.1.3. Drop the Siamese = 5 second penalty.
 - 6.5.2. LADDER CARRY:
 - 6.5.2.1. Ladder touches ground = disqualification.
 - 6.5.2.2. Ladder must be placed in brackets – not thrown = 5 second penalty.
 - 6.5.3. 1 – ¾ " HOSE PULL AND SLED DRAG:



NORTH COUNTY FIRE PROTECTION DISTRICT

POLICY AND PROCEDURE MANUAL

ADMINISTRATION

RULES AND REGULATIONS

CONDITIONS OF EMPLOYMENT

SECTION 223.14

JUNE 12, 2007

PAGE 7 OF 17

PHYSICAL ABILITY EXAMINATION

- 6.5.3.1. Both hands must be on sled handle.
- 6.5.3.2. Employee must pull sled backwards. No walking forward.
- 6.5.3.3. Employee uses hand against tunnel wall = disqualification.
- 6.5.3.4. The rear of the sled must cross the finish line.

6.5.4. CHARGED 2 – ½” HOSE LINE:

- 6.5.4.1. Each time the nozzle touches the ground = 5 second penalty.
- 6.5.4.2. Employee must walk forward. No turning around and pulling the hose backwards.
- 6.5.4.3. Whole foot (one) over the line = disqualification.

6.5.5. LADDER EXTENSION:

- 6.5.5.1. No jumping and grabbing halyard.
- 6.5.5.2. One must hand over hand the fly down. No sliding of the halyard through ones hands = 5 second penalty.
- 6.5.5.3. Ladder bangs ground = 5 second penalty.

6.5.6. BREATHING APPARATUS, HOSE BUNDLE AND STAIRWELL:

- 6.5.6.1. Breathing apparatus – tighten shoulder straps and belt.
- 6.5.6.2. The hose bundle must be flat on the ground.
- 6.5.6.3. The entire hose bundle must go on the shoulder.
- 6.5.6.4. 5-second penalty for each missed step.

6.5.7. HOSE BUNDLE PULL:

- 6.5.7.1. No turning and walking out of pulling area = disqualification.
- 6.5.7.2. Hand breathing apparatus to person on the ground level at foot of stairs.

6.5.8. RESCUE TOOL CARRY:

- 6.5.8.1. Loss of control with extrication tool = disqualification.

6.6. ANY DELIBERATE EQUIPMENT ABUSE = Disqualification.

- 6.6.1. Disqualification is at the Proctor's Discretion.



NORTH COUNTY FIRE PROTECTION DISTRICT

POLICY AND PROCEDURE MANUAL

ADMINISTRATION
RULES AND REGULATIONS
CONDITIONS OF EMPLOYMENT

SECTION 223.14
~~JUNE 12, 2007~~
PAGE 8 OF 17

PHYSICAL ABILITY EXAMINATION

EVENT 1

DRY HOSE DRAG

1.0. EVENT DESCRIPTION:

- 1.1. 150' of 2 ½ uncharged hose will be flaked on the ground.
- 1.2. The employee will place the hose line with the siamese attached over his/her shoulder and grip the siamese coupling with the hands and secure it against the chest area.
- 1.3. Employee will then run/walk 150' in a straight line towards the finish while dragging the hose until the 150' finish line has been reached.
- 1.4. The Siamese must cross the line and be placed on the ground and not dropped.

2.0. SPECIAL INSTRUCTIONS:

- 2.1. Siamese must go beyond the 150 foot finish line.
- 2.2. Utilize the first 4 feet of hose with Siamese attached, not a loop.
- 2.3. If Siamese is dropped to the ground and not placed on the ground a 5 second penalty will result.

3.0. DISQUALIFICATIONS:

- 3.1. None.

4.0. PHYSICAL ABILITIES MEASURED:

- 4.1. Leg strength and cardiovascular endurance.

150'

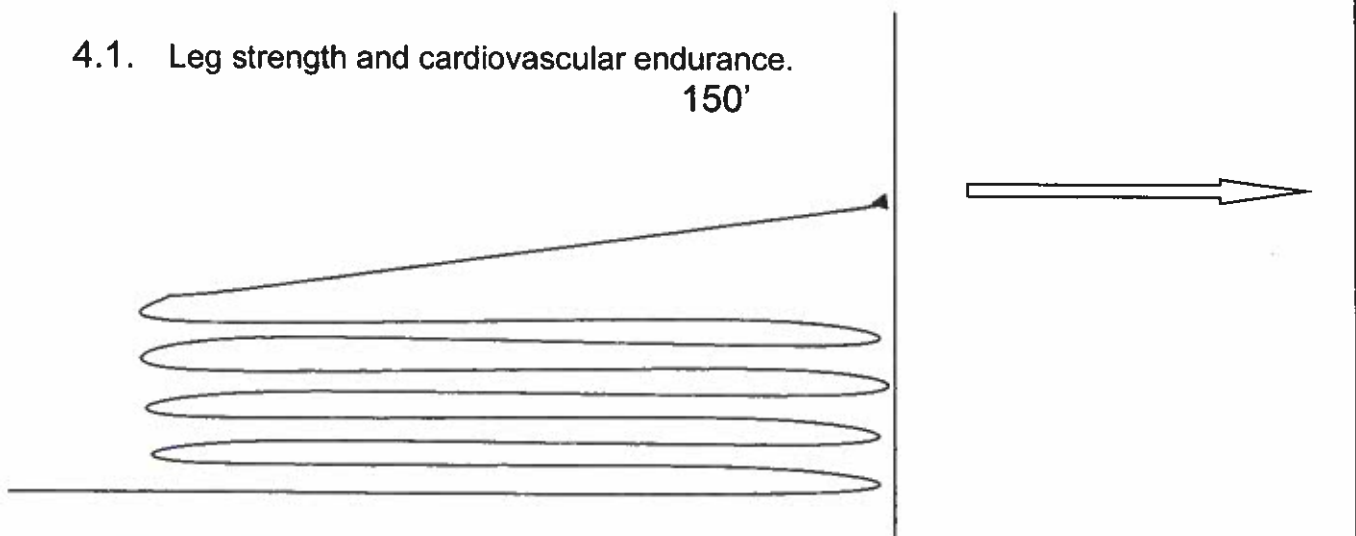



NORTH COUNTY FIRE PROTECTION DISTRICT

POLICY AND PROCEDURE MANUAL

ADMINISTRATION
RULES AND REGULATIONS
CONDITIONS OF EMPLOYMENT

SECTION 223.14

~~JUNE 12, 2007~~

PAGE 9 OF 17

PHYSICAL ABILITY EXAMINATION

EVENT 2

CHARGED 2 ½" HOSE LINE

1.0. EVENT DESCRIPTION:

- 1.1. 50 feet of 2 ½" charged hose will be flaked to facilitate advancement.
- 1.2. The employee will be required to advance the hose forward 25 feet from the starting line.
- 1.3. When the 25 foot marker has been reached the employee will begin a 90 degree right turn and make a 25 foot lateral arc.
- 1.4. The path that the employee will be required to follow will be marked with cones.

2.0. SPECIAL INSTRUCTIONS:

- 2.1. If nozzle touches the ground a 5 second penalty will result.
- 2.2. Employee must walk forward and not turn around and pull the hose backwards.
- 2.3. Do not drop nozzle at finish line
- 2.4. Stay within the course outlined with cones.

3.0. DISQUALIFICATION:

- 3.1. Entire foot over the line.

4.0. PHYSICAL ABILITIES MEASURED:

- 4.1. Leg strength and endurance.

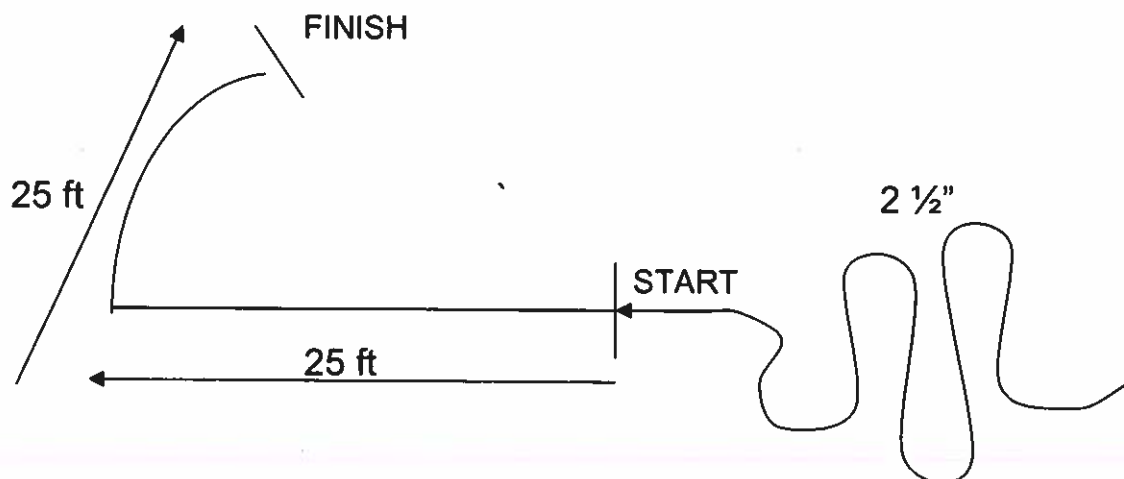



NORTH COUNTY FIRE PROTECTION DISTRICT

POLICY AND PROCEDURE MANUAL

ADMINISTRATION
RULES AND REGULATIONS
CONDITIONS OF EMPLOYMENT

SECTION 223.14

~~JUNE 12, 2007~~

PAGE 10 OF 17

PHYSICAL ABILITY EXAMINATION

EVENT 3

1 1/2" HOSE PULL AND SLED DRAG

1.0. EVENT DESCRIPTION:

- 1.1. The employee will drag a 1 1/2" charged hose line with a nozzle attached 25 feet through a tunnel which is 16 feet in length and 48 inches in height.
- 1.2. A sled weighing 150 pounds will be placed at the opposite end of the tunnel.
- 1.3. The employee will be required to drag the sled 25 feet back through the 16 foot tunnel to the start line.

2.0. SPECIAL INSTRUCTIONS:

- 2.1. Both hands must be on sled handle.
- 2.2. Employee must pull sled backwards and not walking forward.
- 2.3. Do not drop nozzle on ground.
- 2.4. Sled must be pulled across starting line.

3.0. DISQUALIFICATION:

- 3.1. Employee uses hands on tunnel wall for advantage.

4.0. PHYSICAL ABILITIES MEASURED:

- 4.1. Leg, arm, grip and back strength.
- 4.2. Flexibility.
- 4.3. Claustrophobic response.

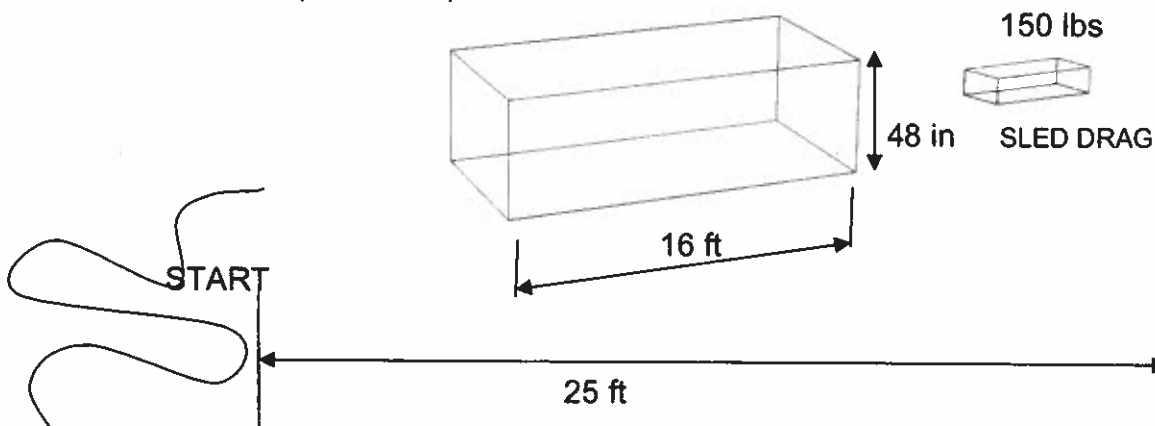



NORTH COUNTY FIRE PROTECTION DISTRICT

POLICY AND PROCEDURE MANUAL

ADMINISTRATION
RULES AND REGULATIONS
CONDITIONS OF EMPLOYMENT

SECTION 223.14

~~JUNE 12, 2007~~

PAGE 11 OF 17

PHYSICAL ABILITY EXAMINATION

EVENT 4

LADDER CARRY

1.0. EVENT DESCRIPTION:

- 1.1. Employee is to lift a 14' roof ladder off a bracket from a height of 5 ½ feet above the ground simulating removal from fire apparatus.
- 1.2. Employee will then carry a 14' ladder a total of 90 feet, 45 feet around a delineator and 45 feet back to bracket where he/she will replace it to the original position on the bracket.

2.0. SPECIAL INSTRUCTIONS:

- 2.1. Ladder must be placed on brackets, not thrown, or a 5 second penalty will result.

3.0. DISQUALIFICATIONS:

- 3.1. If at any time the ladder is dropped it will result in a disqualification.

4.0. PHYSICAL ABILITIES MEASURED:

- 4.1. Legs, arms, grip, chest, back strength and endurance.

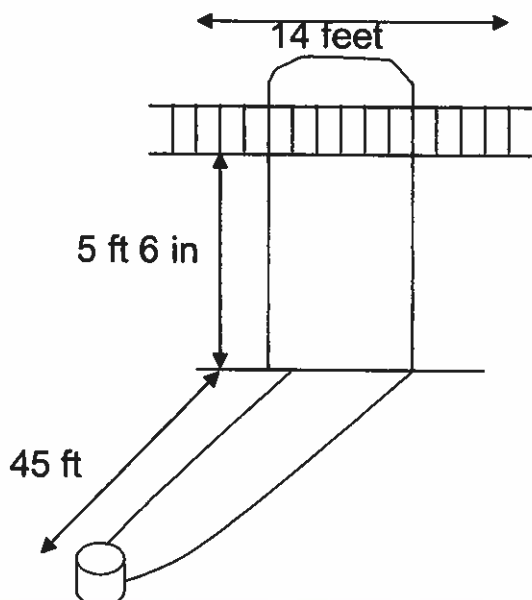



NORTH COUNTY FIRE PROTECTION DISTRICT

POLICY AND PROCEDURE MANUAL

ADMINISTRATION
RULES AND REGULATIONS
CONDITIONS OF EMPLOYMENT

SECTION 223.14

JUNE 12, 2007

PAGE 12 OF 17

PHYSICAL ABILITY EXAMINATION

EVENT 5

RESCUE TOOL CARRY

1.0. EVENT DESCRIPTION:

- 1.1. Candidate picks up simulated rescue tool (73 lbs.) from a 2 foot bench and carries it 45 feet around a deleniator and back 45 feet a distance of 90 feet.
- 1.2. He/she then places tool on a four foot bench.

2.0. SPECIAL INSTRUCTIONS:

- 2.1. Do not drop tool, place it on bench.

3.0. DISQUALIFICATION:

- 3.1. Loss of control with extrication tool

4.0. PHYSICAL ABILITIES MEASURED:

- 4.1. Leg, arm, grip, chest, back strength and endurance.

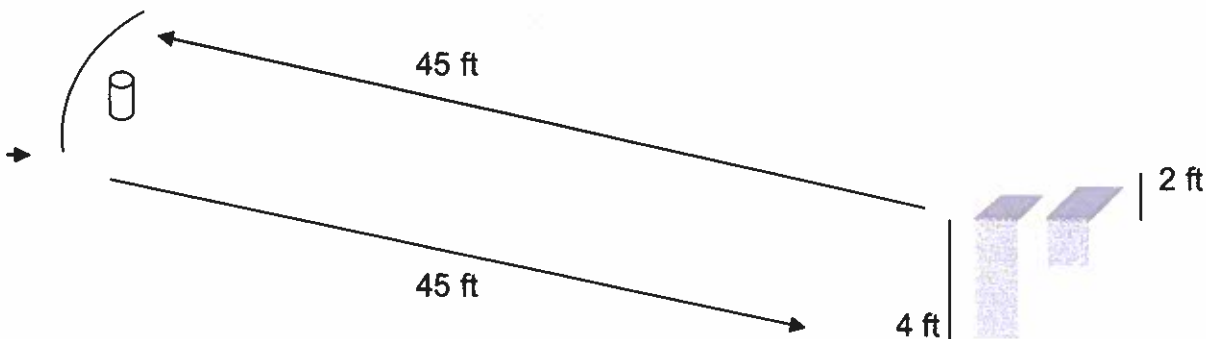



NORTH COUNTY FIRE PROTECTION DISTRICT

POLICY AND PROCEDURE MANUAL

ADMINISTRATION
RULES AND REGULATIONS
CONDITIONS OF EMPLOYMENT

SECTION 223.14

~~JUNE 12, 2007~~

PAGE 13 OF 17

PHYSICAL ABILITY EXAMINATION

EVENT 6

LADDER EXTENSION

1.0. EVENT DESCRIPTION:

- 1.1. Candidate is to fully extend and lower a 28 foot extension ladder.
- 1.2. Ladder will be fixed in an upright position against the maintenance facility east wall.

2.0. SPECIAL INSTRUCTIONS:

- 2.1. While extending the ladder a hand over hand method with thumbs pointing down is preferred.
- 2.2. While lowering the ladder the same method is preferred.
- 2.3. While lowering ladder the halyard should not slip through the gloved hands (5 second penalty).
- 2.4. No jumping and grabbing the halyard.

3.0. PHYSICAL ABILITIES MEASURED:

- 3.1. Grip, arm and back strength.

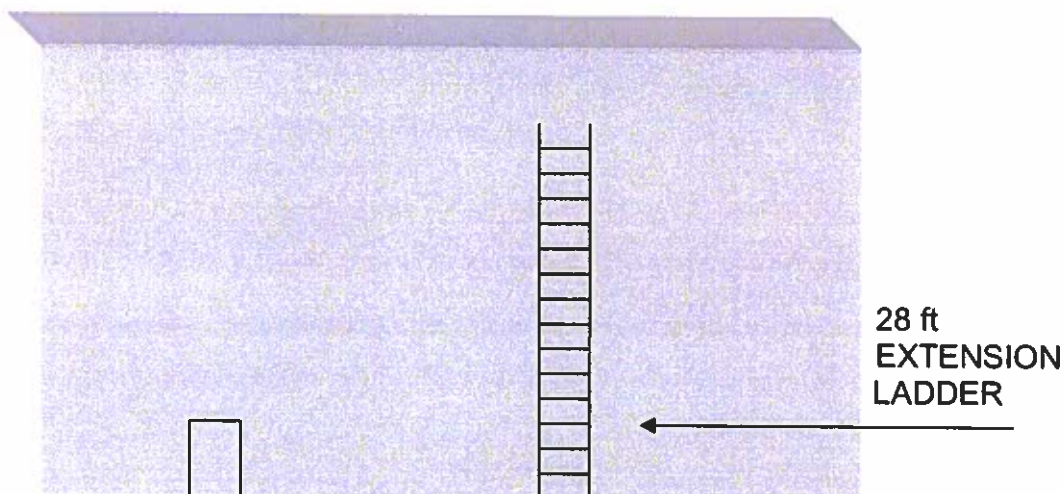



NORTH COUNTY FIRE PROTECTION DISTRICT

POLICY AND PROCEDURE MANUAL

ADMINISTRATION

RULES AND REGULATIONS

CONDITIONS OF EMPLOYMENT

SECTION 223.14

~~JUNE 12, 2007~~

PAGE 14 OF 17

PHYSICAL ABILITY EXAMINATION

EVENT 7

STAIRWELL ADVANCE

1.0. EVENT DESCRIPTION:

- 1.1. Candidate will don S.C.B.A. unassisted.
- 1.2. Candidate must then lift a hose bundle from the ground and place it over his/her shoulder. Prepared hose bundle consists of (1) 50 foot length of 2 ½" (55 lbs.) hose flaked in a 6 foot length and secured with duct tape.
- 1.3. Candidate then proceeds 100 feet around delineator to entrance of stairwell of maintenance facility and climbs stairway to the 4th level rooftop.
- 1.4. Candidate will then drop hose bundle and proceed to the next event.

2.0. SPECIAL INSTRUCTIONS:

- 2.1. All steps must be utilized climbing up and down the tower.
- 2.2. 5 second penalty for missed steps.
- 2.3. Entire hose bundle must go on the shoulder.
- 2.4. Hose bundle must be flat on the ground.
- 2.5. S.C.B.A. shoulder and waist harness must be secure.

3.0. PHYSICAL ABILITIES MEASURED:

- 3.1. Leg strength, cardiovascular endurance.

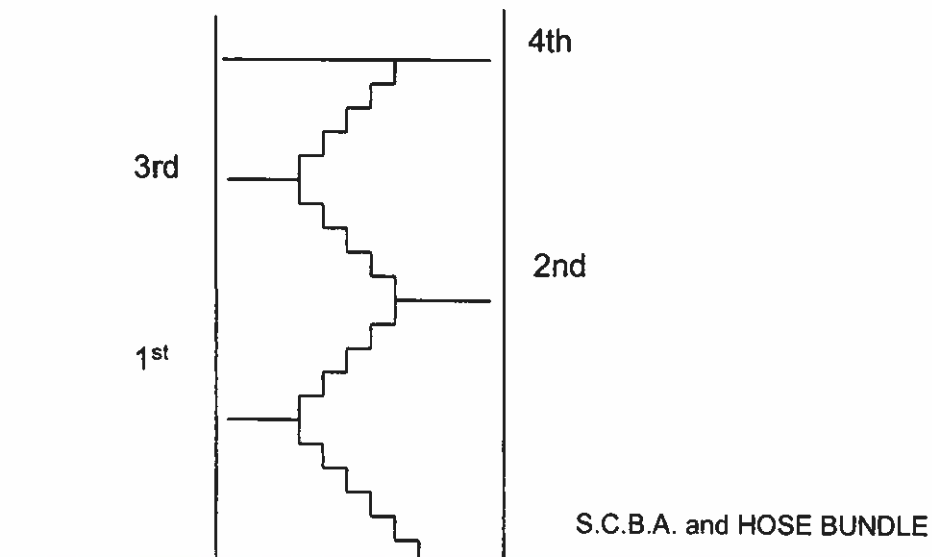



NORTH COUNTY FIRE PROTECTION DISTRICT

POLICY AND PROCEDURE MANUAL

ADMINISTRATION

RULES AND REGULATIONS

CONDITIONS OF EMPLOYMENT

PHYSICAL ABILITY EXAMINATION

SECTION 223.14

~~JUNE 12, 2007~~

PAGE 15 OF 17

EVENT 8

HOSE BUNDLE PULL

1.0. EVENT DESCRIPTION:

- 1.1. After dropping hose bundle, candidate stands on the 4th level rooftop and hoists (1) 50-foot bundle of flaked 2 ½" hose (55 lbs.), from ground level to top of hose roller.
- 1.2. Event ends when proctor secures hose.

2.0. SPECIAL INSTRUCTIONS:

- 2.1. S.C.B.A. stays on until the stairwell descent and will be handed to the proctor at the bottom.

3.0. DISQUALIFICATION:

- 3.1. Employee must stay within the marked pulling area.

4.0. PHYSICAL ABILITIES MEASURED:

- 4.1. Back, arm and grip strength.

Rooftop Maintenance Facility

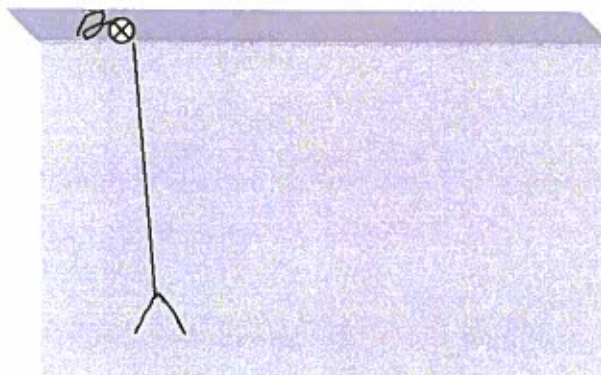



NORTH COUNTY FIRE PROTECTION DISTRICT

POLICY AND PROCEDURE MANUAL

ADMINISTRATION
RULES AND REGULATIONS
CONDITIONS OF EMPLOYMENT

SECTION 223.14
~~JUNE 12, 2007~~
PAGE 16 OF 17

PHYSICAL ABILITY EXAMINATION

Date: _____ EMPLOYEE'S ID: _____

EMPLOYEE'S Last Name: _____ First Name: _____

Age: _____ Height: _____ Weight: _____

Rank: _____ Station: _____ Division: _____

Proctor: _____

MEASUREMENT	PRE TEST	POST TEST	RECOVERED
-------------	----------	-----------	-----------

Heart Rate: _____

Respirations: _____

Blood Pressure: _____

Passed:

Failed:

Reason for Failure: _____

Time of 8 events: _____

<u>MINIMUM STANDARDS:</u>	TIME ALLOWED	TIME ACHIEVED
Firefighter/Paramedic	6:15	_____
Engineer/Paramedic	6:30	_____
Captain/Paramedic	6:45	_____
Chief Officer	7:00	_____



NORTH COUNTY FIRE PROTECTION DISTRICT

POLICY AND PROCEDURE MANUAL

ADMINISTRATION
RULES AND REGULATIONS
CONDITIONS OF EMPLOYMENT

SECTION 223.14
JUNE 12, 2007
PAGE 17 OF 17

PHYSICAL ABILITY EXAMINATION

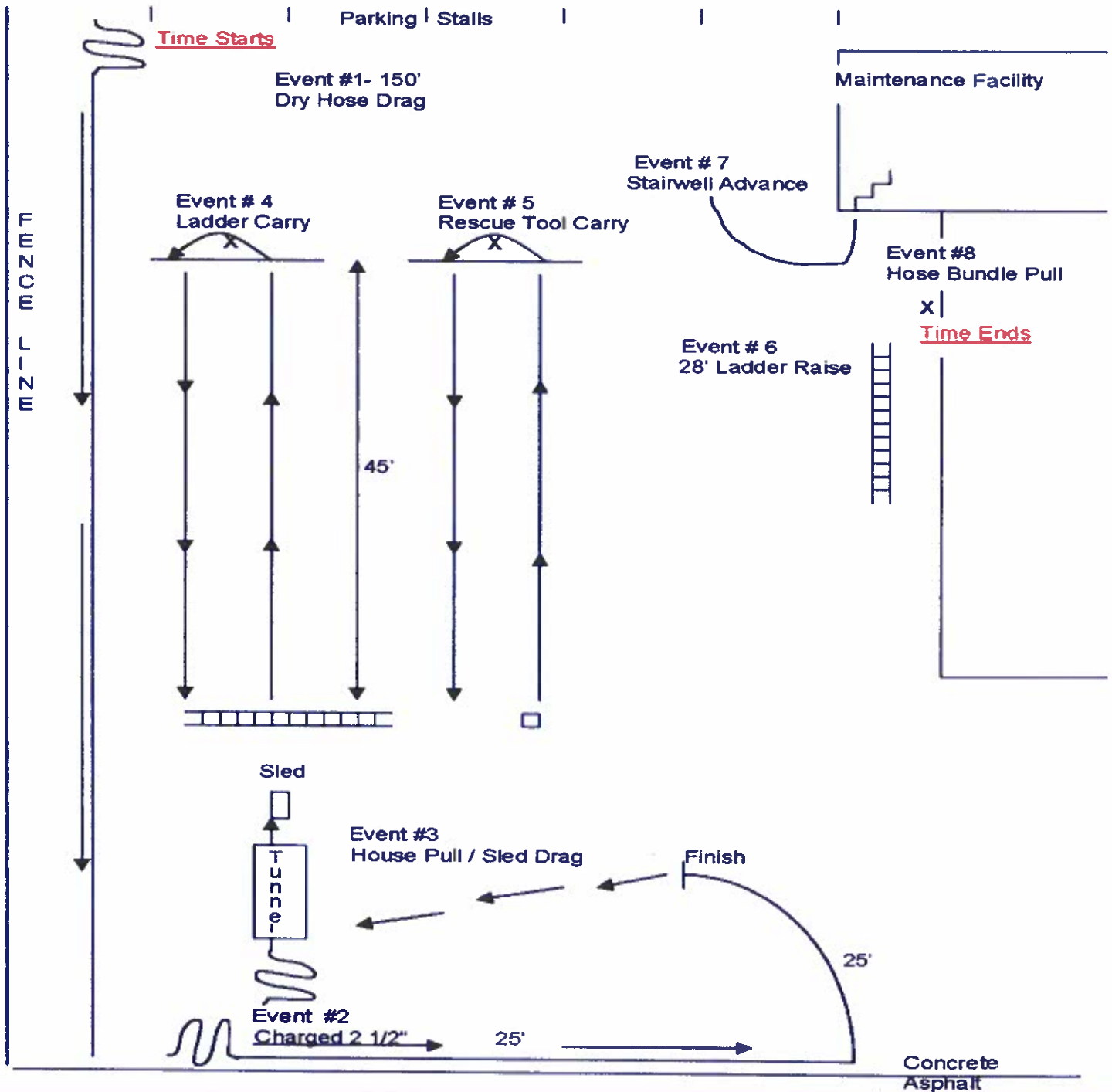

PAGE INTENTIONALLY BLANK

North County Fire



MONTHLY OPERATIONS ACTIVITY REPORT:

Apr 2022

Assigned Incidents

Assigned Incidents for NORTH COUNTY FPD
April 2022

Agency

Month and Year

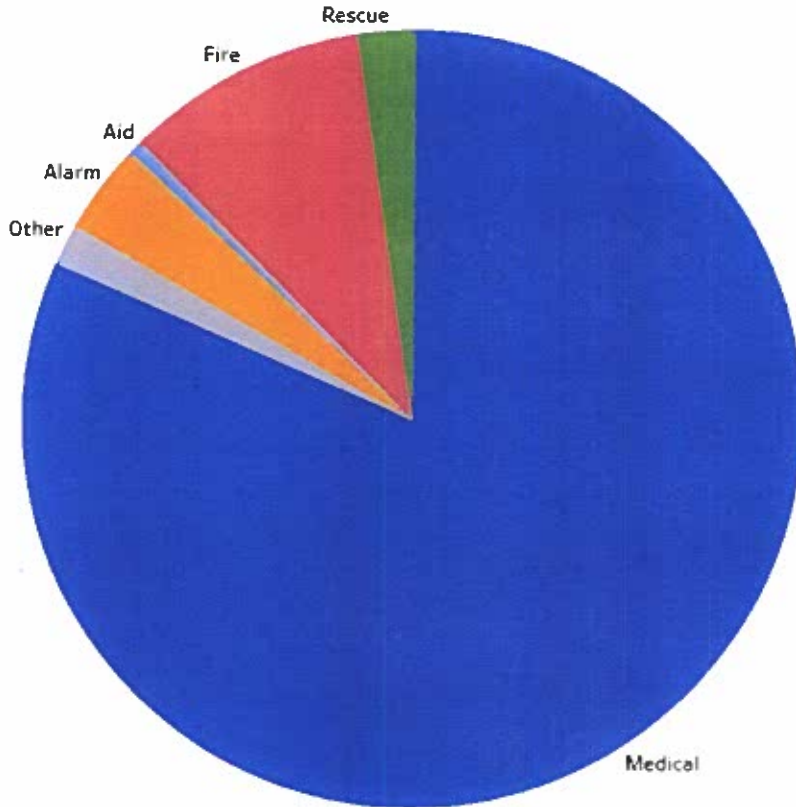

Medical	415 incidents / 81.53%
Fire	51 incidents / 10.02%
Alarm	19 incidents / 3.73%
Aid	3 incidents / 0.59%
Rescue	12 incidents / 2.36%
Other	9 incidents / 1.77%
Grand Total	509 incidents / 100.00%

Problem Category

- Medical
- Other
- Alarm
- Aid
- Fire
- Rescue

Total incidents year to date:
Apr 2021: 1,995
Apr 2022: 2,187



Incidents in Jurisdiction

Incidents in NORTH COUNTY FPD Jurisdiction
April 2022

Jurisdiction
NORTH COUNTY FPD

Month and Year
April 2022

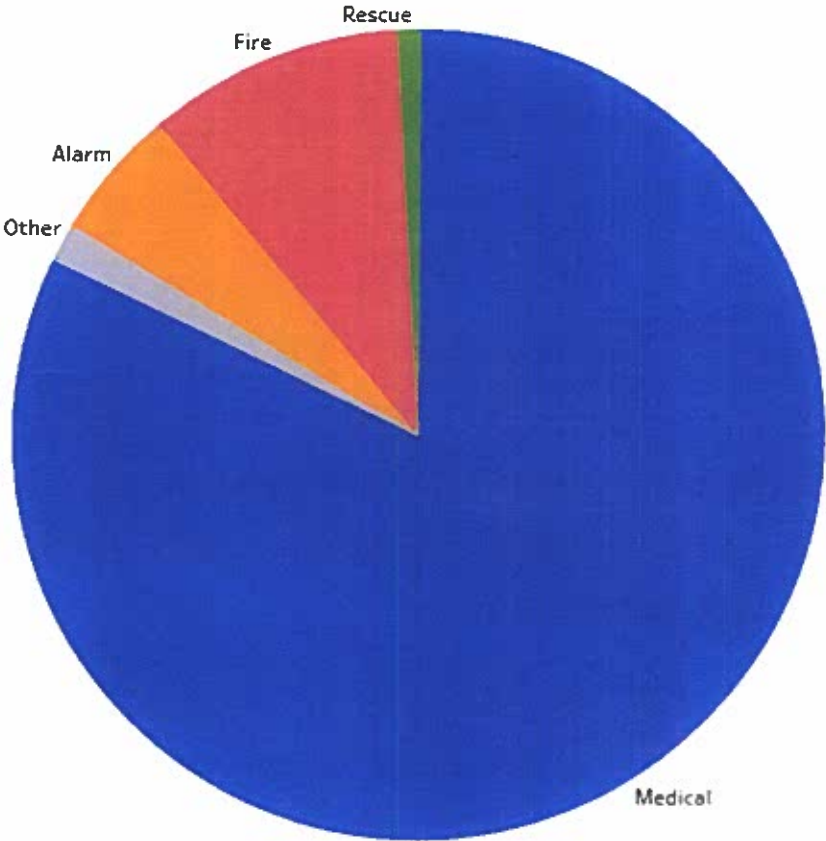

Medical	362 incidents / 82.09%
Fire	45 incidents / 10.20%
Alarm	23 incidents / 5.22%
Rescue	4 incidents / 0.91%
Other	7 incidents / 1.59%
Grand Total	441 incidents / 100.00%

- Problem Category
- Medical
 - Other
 - Alarm
 - Fire
 - Rescue



Turnout Time

(Time of station notification to responding)

90th Percentile – Emergency Calls Only

Shift	Unit Name	April	Shift	Unit Name	April	Shift	Unit Name	April
A-SHIFT	B111	0:00:42 (8)	B-SHIFT	B111	0:01:10 (8)	C-SHIFT	B111	0:01:05 (10)
	E111	0:01:07 (50)		E111	0:01:26 (48)		E111	0:01:24 (38)
	E112	0:01:13 (23)		E112	0:01:07 (20)		E112	0:01:40 (22)
	E113	0:01:27 (11)		E113	0:01:39 (8)		E113	0:01:07 (14)
	E114	0:01:28 (20)		E114	0:01:39 (19)		E114	0:01:16 (17)
	E115	0:01:13 (15)		E115	0:01:19 (16)		E115	0:00:53 (16)
	M111	0:00:09 (1)		M111	0:01:35 (27)		M111	0:01:05 (30)
	M114	0:01:33 (25)		M114	0:01:38 (25)		M114	0:01:09 (23)
	M115	0:01:01 (27)		M115	0:01:16 (22)		M115	0:01:18 (26)
	M116	0:00:24 (1)		RA111	0:01:03 (16)		RA111	0:00:34 (1)
	M117	0:01:07 (3)						
	M118	0:00:07 (1)						
	RA111	0:01:00 (42)						



Aid Given/Received

Aid Given by NORTH COUNTY FPD April 2022 : Incident Count

Jurisdiction (group)	
CAL FIRE	30
CAMP PENDLETON	1
CARLSBAD FD	
ENC/SOL/DMR FD	
ESCONDIDO FD	
NORTH COUNTY FPD	
OCEANSIDE FD	25
PALA FD	3
PAUMA FD	1
RANCHO SANTA FE FPD	
RINCON FD	
SAN DIEGO FD	
SAN MARCOS FD	
SAN PASQUAL RESV FD	
VALLEY CENTER FPD	1
VISTA FD	10
Grand Total	71

Aid Received by NORTH COUNTY FPD April 2022 : Incident Count

Home Jurisdiction	
CAL FIRE	30
CAMP PENDLETON	24
CARLSBAD FD	
ENC/SOL/DMR FD	
ESCONDIDO FD	
NORTH COUNTY FPD	
OCEANSIDE FD	10
PALA FD	5
PAUMA FD	
RANCHO SANTA FE FPD	
RINCON FD	
SAN DIEGO FD	1
SAN MARCOS FD	
SAN PASQUAL RESV FD	
VALLEY CENTER FPD	
VISTA FD	23
Grand Total	95



Incident Volume by Hour

Incident Volume by Hour for NORTH COUNTY FPD
April 2022

Incident Count
1 20

	00	01	02	03	04	05	06	07	08	09	10	11	12	13	14	15	16	17	18	19	20	21	22	23
B111						1		1	2	1	1	2	2	2	1	1	1		1	2	1	2		1
BR112			1																					
BR114			1				1																	
E111	9	3	4	3	1	5	9	6	9	10	5	9	9	11	20	13	13	9	11	11	12	12	8	7
E112	5		1				5	3	2	4	5	7	5	8	7	9	6	8	6	5	2	7	2	1
E113	2	2		1		2	3	1	2	1	5	4	2		2	2	2	1	2		2		1	
E114	4		2	2	1	5	3	3	9	5	4	6	8	8	4	6	5	10	4	8	2	3	4	5
E115	7	1			1	2	3	3	3	7	1	3	5	2	9	3	6	7	2	2	1	7	3	
M111 & RA111	4	3	3	2	1	6	8	5	8	8	6	11	7	12	16	7	10	8	11	10	9	7	7	5
M114 & RA114	3	1	1	3	1	6	5	4	8	2	8	6	5	8	11	5	9	7	7	8	4	2	6	4
M115 & RA115	8	1	1	1	2	3	5	4	3	10	7	7	10	8	13	9	6	8	9	7	7	9	4	1
M117														1	2									

Count of ID broken down by Time Assigned Hour vs. Unit Name.



Incidents by Unit

Incidents by Unit for NORTH COUNTY FPD April 2022

Ambulance	M111 & RA111	174
	M114 & RA114	125
	M115 & RA115	143
	M117	3
	Total	445
Brush	BR112	1
	BR114	2
	Total	3
Engine / Truck	E111	209
	E112	98
	E113	37
	E114	111
	E115	81
	Total	536
Other Units	B111	35
	Total	35
Grand Total		1,019

Count of Time Assigned broken down by Apparatus Type and Unit Name.



Ambulance Unit Hour Utilization

Monthly Unit Hour Utilization for NORTH COUNTY FPD

April 2022	M111 & RA111	27.61%
	M114 & RA114	19.52%
	M115 & RA115	19.48%
	M117	0.19%

Vehicle Type

Ambulance

UHU Ratio



15.00% 35.00%

UHU percentages are calculated only for completed months/years. The current month/year will not show a correct value. Time Committed is calculated by Time Call Cleared minus Time Assigned.



Transports

NORTH COUNTY FPD Transports April 2022

Name	
M111	58
M114	80
M115	85
RA111	52
Grand Total	275

These two tables display a distinct count of ID broken down by Destination. Only transports which arrive at a destination are counted.

NORTH COUNTY FPD Transport Destinations April 2022

Destinations	
TEMECULA VALLEY HOSPITAL	127
PALOMAR HOSPITAL	118
TRI CITY MEDICAL CENTER (TCMC)	23
CHILDRENS HOSPITAL	5
RANCHO SPRINGS HOSP.	3
UCSD	1
SCRIPPS ENCINITAS HOSPITAL	1
MCP NAVAL HOSPITAL	1
Grand Total	275



Health & Safety

Injuries & Illness

2 Injuries

Accidents

1 Vehicle



Transfer of Care

Total Offloads
272

TOC Compliance
89.3%

90th Percentile Offload Time in Minutes
53.4

Median Offload Time in Minutes
26.6

Percent Offloads Under 30 Minutes
56.6%

Percent Offloads Under 20 Minutes
29.0%

San Diego County
Transfer of Care - via FirstWatch
Ambulance Operating Area Data
Use filters below to select data by Ambulance Operating Area, Month, and Year

Ambulance Operating Area

SD COUNTY	AMR Float Units
Barona	Carlsbad
Chula Vista	Coronado
CSA 17	CSA 69
El Cajon	Escondido
GHD Zone 1	Inland Central
Inland North	Inland South
National City	North County FPD
Oceanside	Poway
Ramona	San Diego
San Marcos	Sycuan
Unified Service Area	Viejas

Month

January	February	March
April	May	June
July	August	September
October	November	December

Year

2018	2019	2020	2021	2022
------	------	------	------	------

Ambulance Operating Area Ranking - TOC Compliance
10

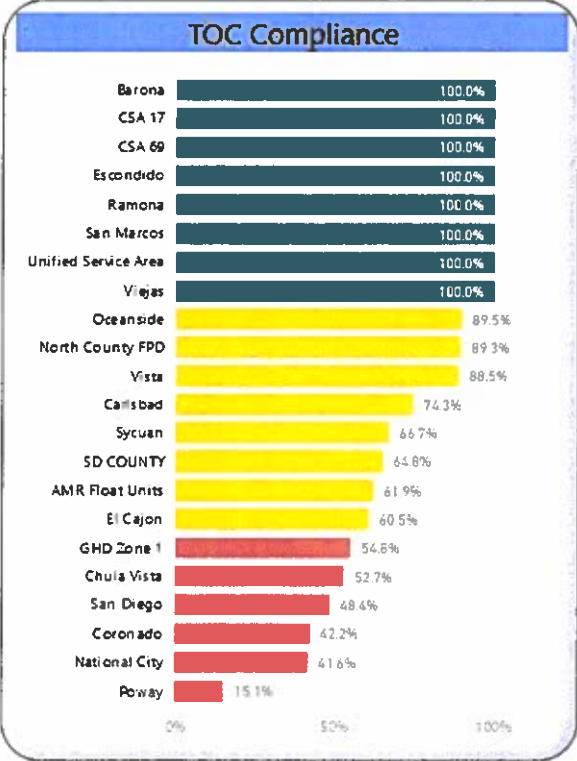

*County data updates later in the month so these stats are 1-month behind



Leadership

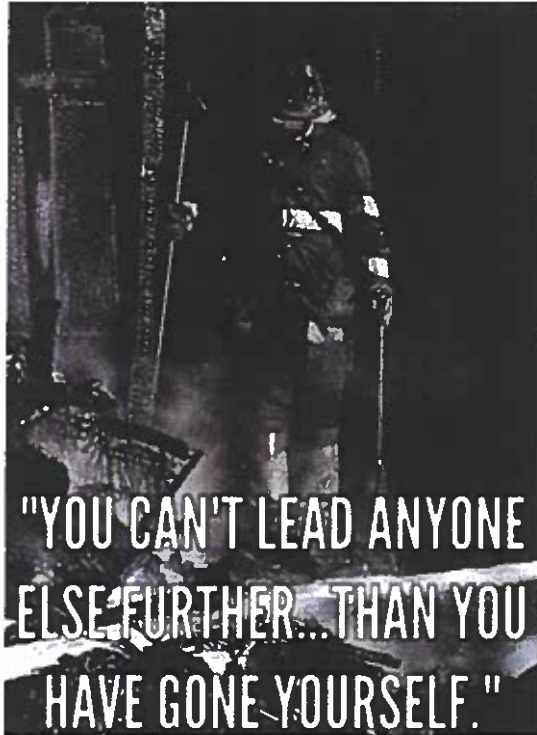



NORTH COUNTY FIRE PROTECTION DISTRICT

OPERATIONS DIVISION STAFF REPORT

TO: BOARD OF DIRECTORS
FROM: FM JUUL, CHIEF MAHR AND CHIEF MCREYNOLDS
DATE: MAY 24, 2022
SUBJECT: PROPERTY/LIABILITY INSURANCE

ACTION AGENDA

RECOMMENDATION:

That the BOD direct Staff to facilitate the transition of the District's property/liability carrier from Special District Risk Management Authority (SDRMA) to Emergency Services Insurance Program (ESIP).

BACKGROUND:

SDRMA is considered a "pooled" insurance carrier that has been covering the NCFPD's property/liability loss since the late 1980's. As a member of a pooled plan the District's rates are impacted by losses incurred by other pool members. Over time, the District has seen steady rate increases from SDRMA with the largest increases occurring from 2018 to 2022. During the last five (5) years SDRMA has raised the District's rates over \$200,000.00.

DISCUSSION:

At the direction of the Board, Staff began researching other property/liability carriers. The District explored options with Risk Strategies who provided a Broker to obtain alternative carriers at no cost to the District. After months of research, Risk Strategies provided the District with three (3) alternative carriers and a recommendation to move from SDRMA to ESIP. ESIP has provided a quote to the District that is significantly less than the current rates being charged by SDRMA for similar coverage. ESIP will be covering the District as an individual entity rather than a member of a pooled plan. As a result, there are some minor differences in coverage as compared to the pooled plan where lower coverage is appropriate to an individual entity rather than a pool.

FISCAL ANALYSIS:

The Fiscal savings that will be realized by the District is anticipated to be approximately \$200,000 for FY 22/23. As a result of the separation from SDRMA, the District will incur the full cost of the North Zone Vector Solutions training program, which is currently covered in our SDRMA rates. The cost of the Vector Solutions program is approximately \$10,000 per year bringing the total savings to the District to \$190,000 for FY22/23.

PROPERTY/LIABILITY INSURANCE
MAY 24, 2022
PAGE 2 OF 2

SUMMARY:

If approved by the Board, the District will execute a service contract with ESIP. Under the new service agreement, the District will transition from a pooled insurance carrier to an individual carrier significantly lowering the District's financial liability for Property/Liability insurance coverage. The transition to ESIP is expected to be completed and implemented by July 1, 2022.



North County Fire Protection District
Property and Liability Presentation

Presented By: Paul Harrison
5/10/2022



Special District Risk Management Agency (SDRMA)

Overview

- SDRMA is a public agency providing Property/Liability, Works Comp, and Health Benefits Programs.
- 499 Individual Public Agencies in Property/Liability Program.
- Communities Services are largest group with 135 agencies, other groups include Flood Control, JPA, Pest Control, Resource Conservation, Sanitary/Sewer/Wastewater, and Water .
- Only 19 Fire Agencies or 3.5% of the pool. (data: 2020-21 SDRMA annual report)

NCFPD Premium History

- 2018-19 \$126,000
- 2019-20 \$167,000
- 2020-21 \$243,000
- 2021-22 \$325,000

PARMA Conference SDRMA March 1, 2022

SDRMA CFO Debbie Yokota Presented (see tab 2)

10 Year Premium vs **10 Year Total Expense**
\$134% Increase \$321.677% Increase

Coverage Providers - Specialize in Fire Service

Experience Matters

We quote three Nationally recognized providers that Specialize in the Fire Service:

FirePlus:

VFIS: Volunteer Firemen's Insurance Services

ESIP: Emergency Services Insurance Program

- As your broker, I have 25 years of experience providing products and services to the CA fire service.
- California State Firefighters Association broker for the past 23 years.
- Risk Strategies is a nationwide brokerage consultant firm with many resources to provide the district with first-in-class programs and services.



Comparison: Property

Regular Board Meeting for May 24, 2021

Lines of Coverage	SDRMA		ESIP	
	Deductible	Limit*	Deductible	Limit
Property	\$1,000	Replacement Cost for Schedule Property \$1,000,000,000	\$1,000**	Guaranteed Replacement Cost (Actual Cash Value Location 1)
Boiler & Machinery (Equipment Breakdown)	\$1,000	\$100,000,000		Included, not to exceed \$500,000
Flood	\$500,000	\$10,000,000	Equal to Building and Business Personal Property per location Limits - \$1,000 deductible (Guaranteed Replacement Cost)	
Pollution Clean Up	\$250,000	\$2,000,000	\$0	\$150,000
Cyber	\$50,000	\$2,000,000 (\$750,000 limits see policy)	\$0	\$1,000,000 Network Security/Data Breach per event Agg \$10M
Computer and Electronic Devices		\$ 75,000 per member (Exhibit F)	\$0	\$250,000 each event
Earthquake		Excluded	\$1,000	Equal to Bld & Personal Prop per location
Total Insured Value: \$13,994,135	* All Limits represent Pool for all SDRMA Districts		** Building 7 subject to \$5,000 deductible	

Comparison: General Liability

Regular Board Meeting for May 24, 2022

Lines of Coverage	SDRMA		ESIP	
	Deductible	Limit*	Deductible	Limit
Umbrella Liability		N/A	\$0	\$4M / \$4M (Pays Excess to coverage below)
Bodily Injury	\$0	\$10,000,000	\$0	\$1,000,000 Occurrence \$10,000,000 Aggregate
Property Damage	\$500	\$10,000,000	\$0	Included in above
Public Officials Personal (D&O)	\$500	\$500,000	\$0	Included in the General Liability Limit
Employment Benefits	\$0	\$10,000,000	\$0	Included in the General Liability Limit
Employee/Public Officials E & O	\$0	\$10,000,000	\$0	Included in the General Liability Limit
Employment Practices Liability	\$0	\$10,000,000	\$0	Included in the General Liability Limit
Pollution Liability	\$250,000	\$2,000,000	\$0	Included in the General Liability Limit

* All Limits represent Pool for All SDRMA Districts

Comparison: **Auto**

	SDRMA		ESIP	
Lines of Coverage	Deductible	Limit*	Deductible	Limit
Auto Physical Damage (Comp)	\$500	Actual Cash Value for Schedule Property	\$500	Actual Cash Value
Auto Physical Damage (Coll)	\$1000	Actual Cash Value for Schedule Property	\$1,000	Actual Cash Value
Auto Liability (includes non-owned auto)				
Auto Bodily Injury	\$0	\$10,000,000	\$0	\$1,000,000
Auto Property Damage	\$1,000	\$10,000,000	\$0	Included in above
Non-Owned Auto Bodily Injury	\$0	\$10,000,000	\$0	Included
Non-Owned Auto Property Damage	\$1,000	\$10,000,000	\$0	Included
Uninsured Motorist	\$0	\$1,000,000	\$0	\$1,000,000

* All Limits represent Pool for all SDRMA Districts

Comparison: Mobile Equipment & Crime

	SDRMA		ESIP	
Lines of Coverage	Deductible	Limit*	Deductible	Limit
Mobile/Contractors Equipment	\$1,000	Actual Cash Value for Schedule Equipment	\$1,000	Guaranteed Replacement Cost
Employee/Public Officials Dishonesty (Crime)	\$0	\$1,000,000	\$0	\$1,000,000

* All Limits represent Pool for all SDRMA Districts

DISCLAIMER: Slides 4-7 Actual coverage is subject to the language of the policies as issued. Your issued policy may contain limits, exclusions, and limitations that are not detailed in this proposal

Comparison: **Pricing**

Renewal: July 1, 2022

	Quote
SDRMA	ESIP
\$325,000	\$128,313
(Existing 2021-22 Premium)	(TRIA "Terrorism" + \$2,663)

For a breakdown of pricing please see the proposals in designated tabs.

A Specialist Approach to Risk



We Take A Different Approach To Keep You Ahead Of Risk

We're a top national broker providing comprehensive insurance and risk management advisory services, and insurance and reinsurance placement for Property & Casualty, Employee Benefits and Private Client risks.

-  3,000+ Employees
-  100+ Locations
-  30+ Specialty Practices
-  100K+ Clients
-  \$5B+ Premiums Placed

Thank you!

This presentation is proprietary and confidential and is not to be disclosed or distributed to the public or any third party without the written consent of Risk Strategies Company. The contents of this presentation are for general informational purposes only and Risk Strategies Company makes no representation or warranty of any kind, express or implied, regarding the accuracy or completeness of any information contained herein. Any recommendations contained in this presentation are intended to provide insight based on currently available information for consideration and should be vetted against applicable legal and business needs before application to a specific client.



Insurance Carrier: Arch Insurance Company: A.M. Best A+(Superior)

Claims Administration: McNeil & Company

McNeil & Company: An owned subsidiary of Arch Capital Group

National Fire Departments: Approximate 3,000 Property and Casualty programs

PROPERTY

ESIP Property provides Guaranteed Replacement Cost coverage for your Real Property (buildings) and Personal Property. Our comprehensive program also provides protection for a wide range of additional property exposures, including:

- Business Income and Extra Expense
- Equipment Breakdown
- Computers and Communications Equipment
- Valuable Papers, Software and Data
- Newly Acquired Property
- Money and Securities
- Flood and Earthquake

COMMERCIAL GENERAL LIABILITY

Designed specifically to meet the special insurance needs of emergency service organizations like yours, ESIP's General Liability coverage goes beyond a standard commercial policy, including:

- Emergency Services Liability (Occurrence or Claims Made basis) – covers such things as, directors and officers liability, employment related practices liability, and employee benefits liability
- Fire and Rescue Service Liability – covers such things as, medical malpractice liability, emergency services errors and omissions, and dispatchers liability
- Pollution Liability and Corrective Action Costs
- Non-Owned Aircraft and Watercraft Liability
- Fellow Member Liability
- Injury to Volunteers

CRIME

Offering Commercial or Government Crime coverage, we expand the definition of employee on our crime policy to include non-compensated officers, directors and board members, treasurers and tax collectors as well as volunteer workers. Coverage is available for the following exposures:

- Employee Theft – Blanket or Position Schedule
- Forgery or Alteration
- Theft of Money and Securities



BUSINESS AUTOMOBILE

ESIP Business Automobile coverage is designed to protect your organization and its members from potential lawsuits arising from motor vehicle accidents and applies to your vehicles as well as those of your members while they are engaged in their duties for you. Coverage for damage to your private passenger type vehicles can also be provided. Available coverage options include:

- Liability Coverage including Hired and Non-Owned
- No Fault / Personal Injury Protection
- Medical Payments Coverage
- Uninsured / Underinsured Motorists Coverage
- Fellow Member Liability
- Injury to Volunteers
- Physical Damage Coverage (including Comprehensive and Collision)
- Full Glass Coverage
- Towing and Labor

EMERGENCY APPARATUS

The Emergency Apparatus coverage in our ESIP policy is designed to provide physical damage coverage for your emergency vehicles on an Agreed Value basis, with a scheduled limit of insurance selected by you. With this coverage, we pay the lesser of the Agreed Value, the actual replacement cost or the repair cost of the vehicle. Numerous coverage enhancements are provided for additional exposures such as:

- Members' Vehicles
- Substitute Apparatus
- Newly Acquired Apparatus
- Hired Apparatus
- Rental Reimbursement
- Towing and Labor
- Full Glass

PORTABLE EQUIPMENT

ESIP Portable Equipment provides Guaranteed Replacement Cost coverage for the property normally used away from your premises in the performance of your duties as an emergency services organization. This covers such things as turnout gear, defibrillators, EMS kits, portable radios and pagers. Additional exposures include:

- Commandeered or Impounded Property
- Members' Property
- Patients' Property
- Scheduled Other Property
- Permanently Installed Property Off Premises
- Computers and Software (away from your premises)

UMBRELLA/EXCESS LIABILITY

Our Umbrella/Excess Liability policy is designed to provide extra limits of insurance above the primary limits provided under our package policy. It also covers damages and any legal defense costs you incur if the coverage under the primary policies is exhausted. Excess limits can be provided for the following:

- Automobile Liability
- Commercial General Liability
- Emergency Services Liability
- Fire and Rescue Service Liability
- Employers Liability



Date: 5/5/2022

Insurance Proposal For:
North County Fire Protection District
330 S Main Ave
Fallbrook, CA 92028

Presented By: Risk Strategies 2270 Douglas Boulevard Suite 220 Roseville, CA 95661 Phone: Fax:	Emergency Services Insurance Program Offered by McNeil & Company, Inc. P.O. Box 5670 67 Main Street Cortland, NY 13045 Phone: (800) 822-3747 Fax: (607) 756-5051 Website: www.esip.com
Carrier: Arch Insurance Company A.M. Best Rating: A+ Superior	

This proposal is valid for 90 days.

DISCLAIMER



GENERAL CONDITIONS:

This proposal is based on information provided to McNeil & Company by your Agent. An application signed and dated by an official of the entity and the agent/broker must be received prior to binding coverage.

The quotation in this proposal does not necessarily match the coverages or limits requested in any bid specifications and/or application.

Each individual policy contains the actual terms, conditions and exclusions. This proposal highlights certain features and benefits of the program.

Final premium is subject to adjustment based on any changes to limits and coverages received subsequent to the release of this proposal.

OUR PROMISE



We developed your Insurance Proposal based on information provided by your ESIP insurance agent. We depend on your agent's knowledge of your organization and on interviews with your organization's personnel, to design the best policy and coverages for you. If you have any questions or concerns about the adequacy or appropriateness of the proposed coverage, please discuss them with your ESIP agent. Many of the policy features can be customized to meet your special needs.

In this proposal we outline the various coverages being offered. However this document can not take the place of an actual policy. Only an actual policy contains all of the terms, conditions, and exclusions that affect your coverage. Please review your policies carefully with your agent to be certain that you clearly understand your insurance program.

We believe that the Emergency Services Insurance Program (ESIP) provides emergency service organizations such as yours with the best insurance products available. We promise that you will find our coverage and service to be beyond your expectations!

For more information about ESIP's products and services, visit us on the Internet at www.esip.com.

NAMED INSURED



Named Insured will read on the policy as:

First Named Insured:

North County Fire Protection District

Other Named Insureds should include all legal entities under which you operate or own property, including any Fire Company, Volunteer Association, Auxiliary, or Cadet Program. If the named insureds shown above are not correct please advise your ESIP agent.

PROPERTY COVERAGE



Limits of Insurance

Building Blanket Limit	\$12,130,162
Contents Blanket Limit	\$2,253,135

Blanket does not apply to the following buildings: 1-1; 1-2

Basic Coverage Information

Coinsurance	Agreed Amount
Building Deductible	\$5,000 Single Occurrence Deductible
Business Personal Property Deductible	\$5,000 Single Occurrence Deductible
Cause of Loss Form:	Special

Additional Terms and Conditions

\$5,000 Property deductible applies to Building & BPP only at location 7. \$1,000 deductible would apply to all other locations

PROPERTY COVERAGE



Limits of Insurance

Premises 1: 231 East Hawthorne, Fallbrook, CA 92028

1 - 1 Meeting House

Building: \$121,223 Business Personal Property: \$26,947

Building Valuation: Actual Cash Value

Business Personal Property Valuation: Guaranteed Replacement Cost

Ordinance or Law Provision: Up to 100% of Direct Damage Amount

1 - 2 Old Shop/Storage

Building: \$241,679 Business Personal Property: \$97,010

Building Valuation: Actual Cash Value

Business Personal Property Valuation: Guaranteed Replacement Cost

Ordinance or Law Provision: Up to 100% of Direct Damage Amount

Flood: \$1,000,000 Per Occurrence and Annual Aggregate \$1,000 Deductible

Earthquake \$1,000,000 Per Occurrence and Annual Aggregate \$1,000 Deductible

Premises 2: 330 Main Street, Fallbrook, CA 92028

2 - 1 Administration Building

Building: \$1,342,266 Business Personal Property: \$107,789

Building Valuation: Guaranteed Replacement Cost

Business Personal Property Valuation: Guaranteed Replacement Cost

Ordinance or Law Provision: Up to 100% of Direct Damage Amount

Flood: \$1,450,055 Per Occurrence and Annual Aggregate \$1,000 Deductible

Earthquake \$1,000,000 Per Occurrence and Annual Aggregate \$1,000 Deductible

PROPERTY COVERAGE



Limits of Insurance

Premises 3: 315 East Ivy Street, Fallbrook, CA 92028

3 - 1 Fire Station 1

Building: \$1,614,375 Business Personal Property: \$282,946

Building Valuation: Guaranteed Replacement Cost

Business Personal Property Valuation: Guaranteed Replacement Cost

Ordinance or Law Provision: Up to 100% of Direct Damage Amount

3 - 2 Service Center

Building: \$2,156,790 Business Personal Property: \$278,816

Building Valuation: Guaranteed Replacement Cost

Business Personal Property Valuation: Guaranteed Replacement Cost

Ordinance or Law Provision: Up to 100% of Direct Damage Amount

3 - 3 Vehicle Canopy

Building: \$68,755 Business Personal Property: \$0

Building Valuation: Guaranteed Replacement Cost

Business Personal Property Valuation: N/A

Ordinance or Law Provision: Up to 100% of Direct Damage Amount

Flood: \$4,378,313 Per Occurrence and Annual Aggregate \$1,000 Deductible

Earthquake \$1,000,000 Per Occurrence and Annual Aggregate \$1,000 Deductible

PROPERTY COVERAGE



Limits of Insurance

Premises 4: 2180 Winterwarm Drive, Fallbrook, CA 92028

4 - 1 Fire Station 2

Building:	\$571,713	Business Personal Property:	\$132,042
Building Valuation: Guaranteed Replacement Cost			
Business Personal Property Valuation: Guaranteed Replacement Cost			
Ordinance or Law Provision: Up to 100% of Direct Damage Amount			
Flood:	\$1,000,000 Per Occurrence and Annual Aggregate	\$1,000 Deductible	
Earthquake	\$1,000,000 Per Occurrence and Annual Aggregate	\$1,000 Deductible	

Premises 5: 2309 Rainbow Valley Blvd, Fallbrook, CA 92028

5 - 1 Fire Station 3

Building:	\$391,494	Business Personal Property:	\$132,042
Building Valuation: Guaranteed Replacement Cost			
Business Personal Property Valuation: Guaranteed Replacement Cost			
Ordinance or Law Provision: Up to 100% of Direct Damage Amount			
Flood:	\$1,000,000 Per Occurrence and Annual Aggregate	\$1,000 Deductible	
Earthquake	\$1,000,000 Per Occurrence and Annual Aggregate	\$1,000 Deductible	

Premises 6: 4375 Pala Mesa Drive, Fallbrook, CA 92028

6 - 1 Fire Station 4

Building:	\$369,086	Business Personal Property:	\$63,758
Building Valuation: Guaranteed Replacement Cost			
Business Personal Property Valuation: Guaranteed Replacement Cost			
Ordinance or Law Provision: Up to 100% of Direct Damage Amount			
Flood:	\$1,000,000 Per Occurrence and Annual Aggregate	\$1,000 Deductible	
Earthquake	\$1,000,000 Per Occurrence and Annual Aggregate	\$1,000 Deductible	

PROPERTY COVERAGE



Limits of Insurance

Premises 7: 5906 Olive Hill Rd, Bonsall, CA 92003

7 - 1 Fire Station 5

Building:	\$5,592,775	Business Personal Property:	\$1,077,890
Building Valuation: Guaranteed Replacement Cost			
Business Personal Property Valuation: Guaranteed Replacement Cost			
Ordinance or Law Provision: Up to 100% of Direct Damage Amount			
Flood:	\$6,670,665	Per Occurrence and Annual Aggregate	\$1,000 Deductible
Earthquake	\$1,000,000	Per Occurrence and Annual Aggregate	\$1,000 Deductible

Premises 8: 311 Minnesota Street, Fallbrook, CA 92028

8 - 1 Satellite Communications Building

Building:	\$22,908	Business Personal Property:	\$53,895
Building Valuation: Guaranteed Replacement Cost			
Business Personal Property Valuation: Functional Replacement Cost			
Ordinance or Law Provision: Up to 100% of Direct Damage Amount			
Flood:	\$1,000,000	Per Occurrence and Annual Aggregate	\$1,000 Deductible
Earthquake	\$1,000,000	Per Occurrence and Annual Aggregate	\$1,000 Deductible

PROPERTY COVERAGE



Coverage Extensions Included

Building Ordinance or Law

- Contingent Loss to the Undamaged Portion of the Building
- Demolition Cost Coverage
- Increased Cost of Construction

Business Income/Extra Expense

Actual Loss Sustained; Up to 24 Months

Applies at:

- Newly Acquired and Constructed Locations
- Non-Owned Fundraising Locations for up to 30 days; No Waiting Period
- Locations of Sirens, Antennas, Towers and Similar Structures

Includes Increased Time Due to Enforcement of an Ordinance or Law

Includes Civil Authority with No Mileage Restriction

Computers and Communications Equipment \$250,000

Broadened Causes of Loss

Software, Data and Valuable Papers Included with No Sub-limit

Broadened Causes of Loss

Equipment Breakdown Coverage Included with No Sub-limit

Heating and Cooling Systems

Telephone Systems

Communication Equipment

Back-Up Generators

Miscellaneous Electrical Equipment

Hazardous Substance Contamination (\$250,000)

Newly Acquired Property \$2,500,000

Up to 180 Days

Material, Equipment and Supplies (\$25,000)

PROPERTY COVERAGE



Coverage Extensions Included

Outdoor Property	\$300,000
Fences	
Monuments and Memorials	
Paved Surfaces such as Parking Lots and Sidewalks	
Trees, Shrubs, Plants and Lawns (\$25,000 Each)	
Property In Transit	\$50,000
Broadened Causes of Loss	
Property Off Premises	\$100,000
Broadened Causes of Loss	
Uncollected Funds	Included With No Sub-Limit
Broadened Causes of Loss	
Pollutant Clean-Up	\$150,000
Debris Removal	\$100,000
Spoilage	\$250,000
Money & Securities	\$50,000
Premises Expanded	1,000 Feet
Outdoor Signs	Included With No Sub-Limit
Fire Extinguishing Equipment	Cost to Recharge; No Sub-Limit
Property of Others	Included With No Sub-Limit
Broadened Causes of Loss (Primary Coverage)	
Sewer and Drain Back Up	Included With No Sub-Limit
Antiquities, Trophies & Awards	Included With No Sub-Limit
Crime Reward	\$25,000

PROPERTY COVERAGE



Coverage Extensions Included

Additional Covered Property	Building & Personal Property Limit
Not to Exceed \$500,000	
Excavations, Grading, Backfilling or Filling	
Foundations of Buildings, Structures, Machinery or Boilers	
Bulkheads, Pilings, Piers, Wharves or Docks	
Retaining Walls that are not part of a Building	
Underground Pipes, Flues or Drains	
Fungus, Wet Rot, Dry Rot or Bacteria	\$50,000
Lock and Key Replacement	\$25,000
Unintentional Omission of Property	\$500,000
Waived Deductible	Up to \$1,000
Waiver applies to not more than 3 claims in any line in any one policy term	
Applies if previous 2 policy periods with us were loss free	
Glass Deductible	Waived if Only Damage
Tenant Glass	\$10,000
Snow Removal Expense	\$1,000 per Policy Period
Inventory or Appraisal	\$50,000
Non-Owned Detached Trailers	\$10,000
Utility Services (Direct Damage)	\$50,000
False Pretense	Included with No Sub-limit
Garages and Storage Sheds	\$10,000
Contents in Garage or Storage Shed \$1,000	
Unscheduled Buildings or Structures Used by the Public	\$100,000
Contents in Unscheduled Buildings or Structures Used by the Public \$10,000	
Preservation of Property	90 Days

GENERAL LIABILITY



Limits of Insurance

General Aggregate	\$10,000,000
Products/Completed Operations Aggregate	\$10,000,000
Each Occurrence	\$1,000,000
Personal & Advertising Injury	\$1,000,000
Damage to Premises Rented to You *	\$100,000
* Damage by Fire, Lightning or Explosion	
Medical Expense	\$10,000

Schedule of all Premises you Own, Rent or Occupy

Location 1: 231 East Hawthorne, Fallbrook, CA 92028

Location 2: 330 Main Street, Fallbrook, CA 92028

Location 3: 315 East Ivy Street, Fallbrook, CA 92028

Location 4: 2180 Winterwarm Drive, Fallbrook, CA 92028

Location 5: 2309 Rainbow Valley Blvd, Fallbrook, CA 92028

Location 6: 4375 Pala Mesa Drive, Fallbrook, CA 92028

Location 7: 5906 Olive Hill Rd, Bonsall, CA 92003

Location 8: 311 Minnesota Street, Fallbrook, CA 92028

GENERAL LIABILITY



Coverages Included

Non-Owned Aircraft & Watercraft

Owned Watercraft less than 35 feet

Owned Unmanned Aircraft (Drones)

Contractual Liability

Fund Raising Activities

Host Liquor Liability

Temporary Liquor Liability for Events Lasting 10 Days or Less

Members as Insureds

Includes Physicians acting within the scope of their duties for Insured

Fire and Rescue Service Liability

Emergency Services E&O

Medical Malpractice Liability

Dispatcher's Liability

Medical Director's E&O

Good Samaritan Liability

Emergency Services Liability - Occurrence

Directors and Officers Liability

Spousal Liability

Estates, Heirs & Legal Representatives Liability

Employee Benefits Liability

Employment Related Practices Liability

Unintentional Release of Individually Identifiable Health Information

Outside Directorships

\$100,000 Non-Monetary Relief

\$100,000 Defense of Suits Involving Fair Labor Standards Act

GENERAL LIABILITY



Coverages Included

Pollution Liability

On-Premises

Includes Above Ground Fuel Storage Tanks

Off-Premises

\$1,000,000 Sub-Limit for Corrective Action Costs

Includes short term pollution events arising from pesticide or herbicide application

Injury to Volunteers

Fellow Member Liability

Bodily Injury and Property Damage

Property Damage to Rented Premises (other than fire) \$50,000

Enhanced Property Damage

Use of Reasonable Force to Protect Persons or Property

Bail Bonds - \$5,000

Your Expenses - \$1,000 per day

Blanket Additional Insured

Persons or Organizations - As Required by Contract

Managers, Landlords or Lessors of Premises

Lessors of Leased Equipment

Waiver of Subrogation

Newly Acquired/Formed Organizations - 180 Days

Duties in the Event of an Occurrence, Offense, Claim or Suit

Limits Persons Required to Give Notice

Liberalization

Bodily Injury Includes Mental Anguish

Coverages Included

Network Security & Data Breach Liability

Network Security & Data Breach Liability Each Event Limit	\$1,000,000
Network Security & Data Breach Liability Aggregate Limit	\$10,000,000
Network Security & Data Breach Liability Retroactive Date	07/01/2022

Provides liability coverage for third party claims or suits involving:

Disclosure, loss or theft of personally identifiable or confidential corporate information in your care, custody or control which is obtained or released from your computer system

Failure to disclose or warn of the actual or potential disclosure or misappropriation of personally identifiable or confidential corporate information

Violation of any federal, state or local privacy statute addressing disclosure or misappropriation of personally identifiable or confidential corporate information

Transmission of malware from your computer system

A denial of service attack which blocks access to your website or computer system

Coverage applies to personally identifiable information of your members.

Coverage applies to events first discovered and reported during the policy period or any extended reporting period.

Privacy Event Mitigation Expense

Privacy Event Mitigation Expense Each Event Limit	\$250,000
Privacy Event Mitigation Expense Aggregate Limit	\$250,000
Privacy Event Mitigation Expense Retroactive Date	07/01/2022

Provides coverage for reasonable and necessary fees and expenses for:

Computer forensic analysis of your computer system to determine the cause and extent of the privacy event

Review of the privacy event by an approved crisis management or legal firm to advise you of the appropriate response

Travel by your directors, executive officers or employees which is done to mitigate the damage of a privacy event

Costs associated with notifying affected parties of the privacy event

Expenses for services, such as credit monitoring, provided to individuals for the purpose of mitigating the effect of a privacy event on them

Coverage applies to events first discovered and reported during the policy period or any extended reporting period.

CRIME



Type of Coverage	Limit of Insurance (no deductible applies)
Employee Theft - Blanket Includes All Employees, Volunteers, Board Members and Treasurers	\$1,000,000
Faithful Performance of Duty	Included
Forgery or Alteration	\$1,000,000
Computer and Funds Transfer Fraud	\$1,000,000
Coverage Extensions	
Credit Card Forgery \$250 Deductible	\$10,000

BUSINESS AUTO



Limits of Insurance

Combined Single Limit Liability (Symbols: 1, 19)	\$1,000,000
Medical Payments (Symbols: 7)	\$10,000
Uninsured Motorists (Symbols: 2)	\$1,000,000
Underinsured Motorists (Symbols: 2)	\$1,000,000

Deductibles (Single Occurrence)

Comprehensive Deductible	\$500
Collision Deductible	\$2,000

BUSINESS AUTO



Vehicle Schedule

No.	Year	Make	Model	VIN	ACV	Agreed Value
1	2008	Ford	Expedition	0687 (X)	X	+
2	2008	Ford	Expedition	0688 (X)	X	+
3	2008	Ford	Expedition	0689 (X)	X	+
4	2008	Ford	Econoline	0834 (X)	X	+
5	2016	Ford	Ambulance	1FDXE4FS0GDC55908	X	+
6	2017	Ford	Ambulance	1FDXE4FS4HDC21357	X	+
7	2017	Ford	Expolorer Intercept.	1FM5K8AR7HGC25123	X	+
8	2003	Ford	F150	2928 (X)	X	+
9	2012	Pierce	Arrow XT w/ Equip.	4P1CA01D3CA012550	X	+
10	2012	Pierce	Saber w/ Equipment	4P1CS01A3CA012731	X	+
11	2008	Pierce	Pumper	6655 (X)	X	+
12	2008	Pierce	Type 1 Engine	8727 (X)	X	+
13	2007	Chevrolet	Silverado	8804 (X)	X	+
14	2002	International	Brush Rig	9972 (X)	X	+
15	2017	Ford	F250 4X4	1FT7W2B64HEC86089	X	+
16	2002	Ford	F150	5064 (X)	X	+
17	2009	Chevy	4500 Ambulance	0072 (X)	X	+
18	2000	Ford	Utility	8705 (X)	X	+
19	2001	Ford	F150	8417 (X)	X	+
20	2005	Ford	Explorer	2545 (X)	X	+
21	2005	Ford	Expedition	2385 (X)	X	+
22	2003	Pierce	Pumper	3328 (X)	X	+
23	2002	International	Brush Rig	9246 (X)	X	+
24	2018	Ford	Ambulance	1FDXE4FS9JDC13129	X	+
25	2018	International	Brush Unit	3HAWETAR5JL631644	X	+
26	2018	Ford	Ford Intercept.	1FM5K8AR9JGB58708	X	+
27	2018	Ford	E450 Ambulance	1FDXE4FS7JDC33122	X	+
28	2019	Pierce	Arrow XT Pumper	4P1BAAFF6KA020426	X	+
29	2019	Pierce	Arrow XT Pumper	4P1BAAFF8KA020427	X	+
30	2019	HME	Type 1 Engine	44KFT428XKWZ23219	X	+
31	2020	Ford	Escape SE FWD	1FMCU0G6XLUA62705	X	+
32	2021	Ford	E-450 Lifeline Unit	1FDXE4FN8MDC00533	X	+
33	2020	Ford	Explorer	1FM5K8AB3LGC13322	X	+

KEY: (X) Invalid Vin; # No Liability Coverage; * Automatic Increase; ^ Towing; + Rental Reimbursement; > GRC; ~ Loan or Lease Gap Coverage;
North County Fire Protection District 7/1/2022

BUSINESS AUTO



Vehicle Schedule

<u>No.</u>	<u>Year</u>	<u>Make</u>	<u>Model</u>	<u>VIN</u>	<u>ACV</u>	<u>Agreed Value</u>	
34	2022	Ford	E-450 Ambulance	1FDXE4FN (X)	X		+
35	2007	Triton	Trailer	4TCSU10407H510921	X		+
36	2006	Pace American	Work Sport Trailer	3920	X		+
37	2006	Lightweight	Trailer	8162	X		+

KEY: (X) Invalid Vin; # No Liability Coverage; * Automatic Increase; ^ Towing; + Rental Reimbursement; > GRC; ~ Loan or Lease Gap Coverage;
North County Fire Protection District 7/1/2022

Included Coverages

Scheduled Vehicles

Non - Owned Vehicles (Primary Liability Including Member's Autos)

Hired / Borrowed Vehicles

Members as Insureds

No Sub-Limit Within 250 Miles

\$2,500 Beyond 250 Miles

\$0 Glass Deductible for Vehicles Carrying Physical Damage

Fellow Member Liability

Rental Reimbursement for ACV Vehicles

\$50 Per Day For 30 Days

Damage to Non-Owned Buildings You Occupy

Garage Liability

Damage to Customer's Autos \$50,000

Pollution Liability

For Pollutants Used in Emergency Operations

Waived Deductible

Up to \$1,000

Waiver applies to not more than 3 claims across all lines in any one policy term

Applies if previous 2 policy periods with us were loss free

Accidental Discharge of an Airbag for Vehicles Carrying Physical Damage

Enhanced Property Damage

Use of Reasonable Force to Protect Persons or Property

Bail Bonds - \$5,000

Your Expenses - \$1,000 per day

Blanket Additional Insured

Persons or Organizations - As Required by Contract

BUSINESS AUTO



Included Coverages

Waiver of Subrogation

Duties in the Event of an Accident, Claim, Suit or Loss

Limits Persons Required to Give Notice

Bodily Injury Includes Mental Anguish

Waiver of Immunity

Applicable to Property Damage Claims of up to \$250,000

Physical Damage Coverage Information

For Agreed Value Vehicles We Pay the Lesser of:

1. Agreed Value

Constructive Total Loss if Repair Cost Equals 75% of Agreed Value

2. Actual Replacement Cost

Including the Cost to Update to Current Standards

3. Repair Cost

Including Up to 50% Extra to Update Damaged Parts to Current Standards

Including the Cost to Recertify

For Actual Cash Value Vehicles We Pay:

1. Actual Cash Value

Including the RCV for Special Paint, Decals and Equipment

Including the Cost to Update to Current Standards

For Guaranteed Replacement Cost Vehicles We Will Increase the Agreed Value to Whatever Amount is Necessary to Equal the Lesser of:

1. Cost of a New Apparatus

Including the Cost to Update to Current Standards

2. Actual Amount Spent for Repair or Replacement

PORTABLE EQUIPMENT



Limits of Insurance

Valuation	Guaranteed Replacement Cost
Deductible (Single Occurrence)	\$1,000

Schedule of Other Property

Valuation	Replacement Cost
Deductible (Single Occurrence)	\$1,000
Kohler Generator #SGM329ZB5	\$50,000
Toyota Forklift	\$38,000
Baldor TS35T Portable Generator #P0708010006	\$21,000

Coverage Extensions

Commandeered and Impounded Property

Primary Coverage

Actual Cash Value or Legal Liability - Whichever is Greater

Adjusted Based on Owner's Policy Provisions if Other Than ACV

Loss of Use and Income

Includes Member's ATV's, Watercraft, Golf Carts and Snowmobiles

Member's Personal Property

Cost to Repair or Replace

\$0 Deductible

Includes ATV's, Watercraft, Golf Carts and Snowmobiles

Patient's Property \$50,000

Computers in Transit \$25,000

Cost to Recertify \$10,000

Permanently Installed Property Off Premises \$200,000

Equipment Breakdown Coverage Included

Drones \$25,000

Additional Living Expenses - Members Up to \$1,000

Deductible Reimbursement - Members Up to \$1,000

Damage to Member's Primary Residence

Responding to, while at or returning from an emergency

Waived Deductible Up to \$1,000

Waiver applies to not more than 3 claims across all lines in any one policy term

Applies if previous 2 policy periods with us were loss free

UMBRELLA LIABILITY



Limits of Insurance

Aggregate*	\$4,000,000
Each Occurrence	\$4,000,000
Personal & Advertising Injury	\$4,000,000
Self Insured Retention	None

* Auto Liability claims are not subject to the aggregate limit

UMBRELLA LIABILITY



Excess Over

Automobile Liability

- Fellow Member Liability
- Garage Liability

General Liability

- Non-Owned Aircraft & Watercraft
- Owned Watercraft up to 35 feet
- Owned Unmanned Aircraft (Drones)
- Contractual Liability
- Host Liquor Liability
- Fellow Member Liability
- Temporary Liquor Liability

Network Security and Data Breach Liability

Emergency Services Liability

- Directors and Officers Liability
- Spousal Liability
- Estates, Heirs & Legal Representatives Liability
- Employee Benefits Liability
- Employment Related Practices Liability
- Unintentional Release of Individually Identifiable Health Information
- Outside Directorships

Pollution Liability

Fire and Rescue Service Liability

- Emergency Services E&O
- Medical Malpractice Liability
- Dispatcher's Liability
- Medical Director's E&O
- Good Samaritan Liability

SAFETY AND TRAINING



McNeil & Co.'s commitment to our client doesn't end with our comprehensive, industry-tailored policies. More than any other insurance company, we want to help you mitigate risk, increase safety, and control losses. We are proud to offer a variety of valuable Risk Management Services with *every policy we write.

ESIP RISK MANAGEMENT SERVICES

- Designated Account Safety Specialist
- Wheelchair Van Safety & Security Checklist
- Motor Vehicle Record (MVR) Reviews *(Available for Business Auto policies)
- Sample Policies & Policy Reviews
- Hazardous Materials & Incident Command Pocket Guides
- Specialized Safety Forms, Checklists, and Self-Inspection Sheets
- Driver Training & Evaluation Info, including EVOC, accident investigation guides, etc.
- Risk Management Surveys & Recommendations, to help identify potential areas of loss
- Employment Practices Hotline
- Alcohol Server Training
- Sample Liability Waivers
- Safety Posters

Don't Forget About



E-Learning is our internet-based training and tracking management platform with instant, 24/7 access to a wide range of courses. This platform enables your members to access vital information and training anywhere with an internet connection, including via most mobile devices. Our management tools empower your organization's leaders to create customized training programs, track user activity, and easily maintain detailed records. We also offer document dropbox for uploading your own policies and training materials. Training specialists are available to help set up E-Learning for your organization, lead system walkthroughs and tutorials, and provide technical support. Best of all, these services come at no additional cost to you!

For more information on our Risk Management Services or E-Learning, visit esip.com or call 1-800-822-3747 ext. 176.

PREMIUM SUMMARY



Policy Premium

	Premium	Includes TRIA of	Fees
Commercial Package	\$110,413	\$2,122	
Commercial Inland Marine	\$11,322	\$276	
Commercial Umbrella	\$6,580	\$265	
Total:	\$128,315	\$2,663*	

*If TRIA is rejected, \$148.00 will be retained for the fire following an act of terrorism.

Additional Coverage Lines Available

- Accident & Health
- Group Life
- 24hr AD&D
- NetSafe Cyber Liability

PAGE INTENTIONALLY BLANK



**NORTH COUNTY FIRE
PROTECTION DISTRICT**

FIRE PREVENTION BUREAU

TO: BOARD OF DIRECTORS
FROM: F/M FIERI AND CHIEF McREYNOLDS
DATE: MAY 24, 2022
SUBJECT: FIRE PREVENTION PROGRAMS: SET PUBLIC HEARING DATE FOR FIRE MITIGATION PLAN

ACTION AGENDA

RECOMMENDATION:

- **Fire Mitigation Program:** Set public hearing date of **July 26, 2022 at 4:05 p.m.** for the adoption of Resolution establishing a Multi-Year Facilities and Equipment Plan for the Fire Mitigation Program.

BACKGROUND:

The District is required to adopt a Multi-Year Facilities and Equipment Plan to participate in the County Fire Mitigation Fee Program. The Multi-Year Plan is required to be updated annually.

DISCUSSION:

Adoption of a Multi-Year Plan and the Annual Report permits the District to continue to participate in the Fire Mitigation Fee Program. This allows the District to collect developer impact fees to offset the increased demands upon the District's infrastructure. Documentation supporting the fee schedule for Mitigation Fees and the Multi-Year Plan will be presented at the July meeting.

FISCAL ANALYSIS: No fiscal changes at this time.

SUMMARY:

- Staff recommends setting a time certain public hearing date of **July 26, 2022 at 4:05 p.m.** for the adoption Resolution establishing a Multi-Year Facilities and Equipment Plan for the Fire Mitigation Program.

NORTH COUNTY FIRE PROTECTION DISTRICT

330 S. Main Avenue • Fallbrook, California 92028-2938 • Phone: (760) 723-2005 • Fax: 760) 723-2072 • Web: www.ncfire.org

BOARD OF DIRECTORS

CINDY ACOSTA
JEFF EGKAN
DAVID KENNEDY
KENNETH E. MUNSON
JOHN VAN DOORN

STEPHEN J. ABBOTT - Fire Chief/CEO - sabbot@ncfire.org
ROBERT H. JAMES - District Counsel - roberthjameslaw@gmail.com
LOREN A. STEPHEN-PORTER - Executive Assistant/Board Secretary - lstephen@ncfire.org

PUBLIC NOTICE

NOTICE IS HEREBY GIVEN THAT THE BOARD OF DIRECTORS OF THE NORTH COUNTY FIRE PROTECTION DISTRICT, 330 South Main Avenue, Fallbrook, California, County of San Diego, will conduct a Public Hearing on **Tuesday, July 26, 2022, at a time certain of 4:05 p.m.** at the Fallbrook Public Utility District, 990 East Mission Road, Fallbrook, California, adopting a Resolution establishing a **Multi-Year Facilities and Equipment Plan for the Fire Mitigation Fee Program** to comply with Government Code §§66000-66002 and the County of San Diego Fire Mitigation Fee Ordinance.

Any taxpayer may appear at said time and place and be heard regarding this item.

Dominic Fieri, Fire Marshal
North County Fire Protection District
(760) 723-2010

BY ORDER OF THE BOARD OF DIRECTORS OF THE NORTH COUNTY FIRE PROTECTION DISTRICT.

Loren Stephen-Porter
Board Secretary
Dated: May 24, 2022

CERTIFICATION OF POSTING

"I certify that this Notice was posted at the following locations: [1] the entrance of North County Fire Protection District Administrative Offices, [2] Fallbrook Public Utility District Administrative Offices and [3] the Roy Noon Meeting Hall, [4] District's website at <https://www.ncfire.org>. The date of posting was **May 25, 2022.**"

Board Secretary Loren Stephen-Porter:



Date: May 25, 2022



PROUDLY SERVING THE COMMUNITIES OF FALLBROOK, BONSALE AND RAINBOW

DUTY ~ INTEGRITY ~ RESPECT



**NORTH COUNTY FIRE
PROTECTION DISTRICT
FIRE PREVENTION BUREAU**

TO: BOARD OF DIRECTORS
FROM: FM FIERI AND CHIEF MC REYNOLDS
DATE: MAY 24, 2022
SUBJECT: APPROVE/AUTHORIZE FIXED CHARGE SPECIAL ASSESSMENT FOR WEED ABATEMENT

ACTION AGENDA

RECOMMENDATION:

Staff recommends the Board approve and authorize the Administrative Staff to deliver the Fixed Charge Special Assessment forms to San Diego Property Tax Services on or before the deadline of August 10th, 2022.

BACKGROUND:

Community Risk Reduction is responsible for the annual weed abatement of properties with hazardous growth that is not maintained by property owners. Throughout the year, Staff has mailed weed abatement notices to those property owners who have a known or existing fire hazard on their parcel(s). The District maintains a Special Services Agreement with California Tree Services, Inc. to bring specifically hazardous properties into compliance with North County Fire Protection District's Ordinance No. 2000-01.

Property owners are required to remove dead/dying vegetation and annual growth from their property, maintaining the parcel in accordance with the District's Ordinance. Those who have failed to comply with District notices to abate within a specified time period have been brought to compliance by the District's Special Service contractor. The property owners have been invoiced for the final costs and fees associated with abating their parcel.

DISCUSSION:

The majority of property owners who received a Notice to Abate willingly complied within the timeframe allowed; however, some parcels were cleared by the Fire District. Administrative Staff has mailed courtesy notices and invoices requesting payment to the following non-compliant property owners:

**APPROVE/AUTHORIZE FIXED CHARGE SPECIAL ASSESSMENT FOR WEED ABATEMENT
MAY 24, 2022
Page 2 Of 2**

APN	COST TO ABATE	ADMIN FEES	TOTAL
1026103000	\$10,400.00	\$756.00	\$11,156.00
1242012900	\$13,000.00	\$756.00	\$13,756.00
TOTAL	\$23,400.00	\$1,512.00	\$24,912.00

A final request for payment will be sent to the property owners noting the June 30th payment deadline. A list of non-compliant owners will be publicly posted a minimum (3) days prior to the May 24th Board meeting as well as a minimum (3) days before the June 28th Board meeting. Those property owners who fail to pay by this date will remain on the list, which will be delivered to the County of San Diego no later than August 10th, 2022. The Board will be presented with the final list of properties eligible for the Special Tax Assessment at the June Board Meeting.

The County of San Diego will reimburse the Fire District for all applicable charges, including the administrative fees, and will include them on the owner's next property tax bill.

ATTACHMENTS:

1. Abatement Packets originally submitted to Chief McReynolds
2. Invoices from California Tree Services
3. Receipts for Payments made by North County Fire
4. County required form - Attachment B
5. Certification of Fixed Charge Special Assessment - Attachment E

NORTH COUNTY FIRE PROTECTION DISTRICT

330 S. Main Avenue • Fallbrook, California 92028-2938 • Phone: (760) 723-2005 • Fax: (760) 723-2072 • Web: www.ncfire.org

BOARD OF DIRECTORS

CINDY ACOSTA
JEFFERY EGKAN
DAVID KENNEDY
KENNETH E. MUNSON
JOHN VAN DOORN

KEITH MCREYNOLDS - Fire Chief/CEO - kmcreynolds@ncfire.org
ROBERT H. JAMES - District Counsel - roberthjameslaw@gmail.com
LOREN A. STEPHEN-PORTER - Executive Assistant/Board Secretary - lstephen@ncfire.org

NOTICE OF WEED ABATEMENT SPECIAL ASSESSMENT LISTING

The following parcel numbers will be sent to the County of San Diego as a special assessment on property taxes unless paid by close of business day **June 30, 2022**.

APN	COST TO ABATE	ADMIN FEES	TOTAL
1026103000	\$10,400.00	\$756.00	\$11,156.00
1242012900	\$13,000.00	\$756.00	\$13,756.00
TOTAL			

Loren Stephen-Porter
Board Secretary
Posted: May 18, 2022

CERTIFICATION OF POSTING

"I certify that this Notice was posted at the following locations: [1] the entrance of North County Fire Protection District Administrative Offices, [2] Fallbrook Public Utility District Administrative Offices and [3] the Roy Noon Meeting Hall, [4] District's website at <http://www.ncfire.org> The date of posting was **May 18, 2022**."

Board Secretary Loren Stephen-Porter:



Date: May 18, 2022



PROUDLY SERVING THE COMMUNITIES OF FALLBROOK, BONSALE AND RAINBOW

DUTY ~ INTEGRITY ~ RESPECT



NORTH COUNTY FIRE PROTECTION DISTRICT
 330 South Main Ave. Fallbrook, CA 92028
 Prevention Division

FINAL NOTICE - AFTER FORCED ABATEMENT

05 17 2022

Amber N. Lisak
 2945 Vista Del Rio
 Fallbrook, CA 92028

APN: 102610300

DATE	AMOUNT	UNITS	DESCRIPTION	TOTAL
11 6 2021	\$ 756.00	1	Forced Weed Abatement - Admin Fee	\$ 756.00
12 7 2021	\$ 4,000.00	1	Abatement Work	\$ 4,000.00
12 7 2021	\$ 6,400.00	1	Abatement Work	\$ 6,400.00
				\$ -
				\$ -
				\$ -
				\$ -
				\$ -
*TOTAL:				\$ 11,156.00

*Note: The non-compliance weed abatement reinspections have already been submitted to a third party cost recovery organization and are not included in this amount.

FINAL NOTICE - AFTER FORCED ABATEMENT

Your cooperation is expected. Failure to pay or correct by **June 28, 2022** will make you liable to the penalties provided by law and subject to forced abatement procedures in accordance with the Consolidated San Diego County Fire Code, Division II, Appendix II-A and NCFPD Ordinance 2000-01.

California Tree Service, Inc

P.O. Box 2019
San Marcos, CA 92079-2019

Invoice

Date	Invoice #
12/30/2021	Lisak-21-1

Bill To

**North County Fire
Protection District
330 S Main Ave
Fallbrook, CA 92028**

Ship To
Same Parcel #102-610-30-00

P.O. No.	Terms	Due Date	Job #
M-515	Due on receipt	12/30/2021	

Quantity	Description	Rate	Serviced	Class	Amount
	Day Rate - Mulcher for tree limbs - 4 days 32 hours @ \$125.00/per hour 12/2/21-12/7/21	4,000.00			4,000.00
	Day Rate-Labor for cutting trees - 4 days 4 men, 32 hours @ \$50.00/per hour 12/1/21-12/7/21	6,400.00			6,400.00

Total		\$10,400.00
Payments/Credits		\$0.00
Balance Due		\$10,400.00

Tax ID#33-0590043

Phone #	Fax #	E-mail	Web Site
760-510-8100	760-746-2867	caltree222@yahoo.com	www.caltreeservice.com

California Tree Service, Inc
P.O. Box 2019
San Marcos, CA 92079-2019

BM To
Amber N Link
2945 Vista Del Rio
Fallbrook, CA 92028

520287974445



U.S. POSTAGE PAID
SAN MARCOS, CA
92079
\$7.38
R237812458 17

POSTAL RECEIPT
REQUESTED

2019

RTS
VAC
2/1

911 NFE 1 C28F7203/18/22
FORWARD TIME EXP RTH TO SEND
LISAK AMBER NOELLE
5899 AMBROSIA LN APT 220
CARLSBAD CA 92011-2626

RETURN TO SENDER

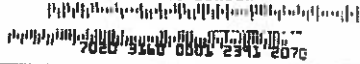

SAN DIEGO CA 920
29 FEB 2022



7013 0470 0000 0812 9765

California Tree Service, Inc
P.O. Box 2019
San Marcos, CA 92079-2019

VL 2-28

310 NFE 1 C18C0882/22/22
FORWARD TIME EXP RTH TO SEND
LISAK AMBER NOELLE
5899 AMBROSIA LN APT 220
CARLSBAD CA 92011-2626

RETURN TO SENDER

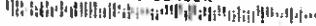

320287974445



U.S. POSTAGE PAID
SAN MARCOS, CA
92079
\$7.38
R237812458 17

SAN DIEGO CA 920

California Tree Service, Inc
P.O. Box 2019
San Marcos, CA 92079-2019



U.S. POSTAGE PAID
SAN MARCOS, CA
92079
\$7.38
R237812458 17

BM To
Amber N Link
2945 Vista Del Rio
Fallbrook, CA 92028

920287974445

7020 3160 0001 5621 0334

910 NFE 1 C20T0001/07/22
FORWARD TIME EXP RTH TO SEND
LISAK AMBER NOELLE
5899 AMBROSIA LN APT 220
CARLSBAD CA 92011-2626

RETURN TO SENDER





North County Fire Protection District

330 South Main Avenue • Fallbrook • California 92028
Tel (760) 723-2010 • Fax (760) 723-2045

Board of Directors
Cindy Acosta
Jeffery Eghan
David Kennedy
Kenneth E. Munson
John Van Doorn

Fire Chief
Keith McReynolds

NOTICE OF PENDING FORCED ABATEMENT AND DUE BILL

NOTE: THIS IS NOT A NOTICE TO GRADE YOUR PROPERTY

Dear: LISAK AMBER N

Date: 10/27/2021

Parcel: 1026103000

San Diego County Property records show you as owner of the parcel number listed above. A series of recent inspections determined that fire hazard(s) exist on your property as defined in North County Fire Protection District's *Ordinance 2000-01* for abatement of public nuisances. Visit www.ncfire.org to view Ordinance 2000-01 in its entirety

LOCATION OF HAZARD: 2945 VISTA DEL RIO

INSTRUCTION FOR ABATEMENT: PLEASE SEE REVERSE SIDE OF NOTICE

AT LEAST TWO SEPARATE NOTICES HAVE BEEN SENT TO THE PROPERTY OWNER OF RECORD AND/OR POSTED ON YOUR PROPERTY ADVISING OF THE NEED TO ABATE FIRE HAZARDS BY THE POSTED DEADLINE. AS A RESULT OF FAILURE TO COMPLY WITH THESE NOTICES, THIS PROPERTY IS NOW SCHEDULED FOR FORCED ABATEMENT OF THESE HAZARDS. ABATEMENT WILL OCCUR ON OR AFTER TEN (10) DAYS FROM THE DATE OF THIS NOTICE. AT THIS TIME, YOU ARE RESPONSIBLE FOR PAYMENT OF NON-COMPLIANCE INSPECTION EXPENSES INCURRED BY THE DISTRICT AS WELL AS ASSOCIATED ADMINISTRATIVE CHARGES.

DATE	DESCRIPTION	TOTAL
11/6/2021	Non-Compliance Weed Abatement Reinspection	\$364.50
11/6/2021	Forced Weed Abatement Administrative Fee	\$774.50

If payment is not received from you, these inspection and administrative charges will be placed on the parcel by the County Auditor and collected at the time and in the manner of ordinary property taxes. Additionally, you will also be responsible for forced abatement charges incurred by the Fire District to abate the fire hazards present on your property.

If you do not own this property, have already cleared this property, feel you have received this notice in error, or wish to schedule an on-site meeting, please contact the Fire Prevention Bureau at 760-723-2010 as soon as possible. Additionally, should you disagree with the determination that a hazard exists, you may request an administrative review with the Fire Marshal.

Sincerely,

Stephen Abbott, Fire Chief

WARNING – ENVIRONMENTALLY PROTECTED PLANTS OR ANIMAL SPECIES

Clearing of vegetation as required by this letter that contains threatened or endangered species is subject to the Memorandum of Understanding (MOU) with the U.S. Fish and Wildlife Service (USFWS) and California Department of Fish and Game (CDFG). Deliberate take or clearing or removal beyond that specifically allowed by this notice and the MOU is not authorized and may be in violation of the State and Federal Endangered Species Act. Please contact the fire district with questions about compliance with the MOU and this notice. You should also contact USFWS at (760) 431-9440 or CDFG (858) 467-4201 if you have been notified that you have a threatened or endangered species on your property.



North County Fire Protection District

330 South Main Avenue • Fallbrook • California 92028
Tel (760) 723-2010 • Fax (760) 723-2045

Board of Directors

Cindy Acosta
Jeffery Eghan
David Kennedy
Kenneth E. Munson
John Van Doorn

Fire Chief

Keith McReynolds

NOTICE TO ABATE HAZARD – FINAL NOTICE

NOTE: THIS IS NOT A NOTICE TO GRADE YOUR PROPERTY

Date: 9/28/2021

Dear: LISAK AMBER N
2945 VISTA DEL RIO
FALLBROOK CA 92028

Parcel: 1026103000

San Diego County Property records show you as owner of the parcel number listed above. A recent survey determined that fire hazard(s) exist on your property as defined in North County Fire Protection District's *Ordinance 2000-1* for vegetation management.

LOCATION OF HAZARD: 2945 VISTA DEL RIO

PLEASE SEE REVERSE SIDE OF NOTICE FOR INSTRUCTION FOR ABATEMENT

(Visit www.ncfire.org to view Ordinance 2000-1 in its entirety).

THIS IS CONSIDERED FINAL NOTICE to abate the aforementioned fire hazard(s) on your property. Hazard abatement must be accomplished within 10 days of this notice. Properties that have not been cleared or do not comply with the requirements within 10 days will be subject to the district's *Forced Abatement Process*. Property owners are strongly urged to arrange for the clearing of their own parcels, as the above requirements are strictly enforced. **NOTICE HAS BEEN SENT TO THE PROPERTY OWNER OF RECORD AND/OR POSTED ON YOUR PROPERTY ADVISING OF THE NEED TO ABATE FIRE HAZARDS BY THE POSTED DEADLINE. YOU ARE RESPONSIBLE FOR PAYMENT OF NON-COMPLIANCE REINSPECTION EXPENSES INCURRED BY THE DISTRICT.**

DATE	DESCRIPTION	TOTAL
10/8/2021	Non-Compliance Weed Abatement Reinspection	\$364.50

Should you choose not to abate the above hazard, nor make an appeal, the fire chief is authorized to hire a contractor to abate the hazard. The cost of abatement and a \$774.50 administrative fee for each parcel will be assessed to your property. If payment is not received from you, these charges will be placed on the parcel by the County Auditor and collected at the time and in the manner of ordinary property taxes.

If you do not own this property, have already cleared this property, feel you have received this notice in error, or wish to schedule an on-site meeting, please contact the Fire Prevention Bureau at (760) 723-2010 as soon as possible. Additionally, should you disagree with the determination that a hazard exists, you may request an administrative review with the Fire Marshal. Please include your property address and the inspector listed at the bottom of this notice with all inquiries.

Sincerely,
Lars Beeghley, NCFPD

WARNING – ENVIRONMENTALLY PROTECTED PLANTS OR ANIMAL SPECIES

Clearing of vegetation as required by this letter that contains threatened or endangered species is subject to the Memorandum of Understanding (MOU) with the U.S. Fish and Wildlife Service (USFWS) and California Department of Fish and Game (CDFG). Deliberate take or clearing or removal beyond that specifically allowed by this notice and the MOU is not authorized and may be in violation of the State and Federal Endangered Species Act. Please contact the fire district with questions about compliance with the MOU and this notice. You should also contact USFWS at (760) 431-9440 or CDFG (858) 467-4201 if you have been notified that you have a threatened or endangered species on your property.



North County Fire Protection District

330 South Main Avenue • Fallbrook • California 92028
Tel (760) 723-2010 • Fax (760) 723-2045

Board of Directors
Cindy Acosta
Jeffery Eghan
David Kennedy
Kenneth E. Munson
John Van Doorn

Fire Chief
Keith McReynolds

NOTICE TO ABATE HAZARD – SECOND NOTICE

NOTE: THIS IS NOT A NOTICE TO GRADE YOUR PROPERTY

Date: 8/24/2021

Dear: LISAK AMBER N
2945 VISTA DEL RIO
FALLBROOK CA 92028

Parcel: 1026103000

San Diego County Property records show you as owner of the parcel number listed above. A recent survey determined that fire hazard(s) exist on your property as defined in North County Fire Protection District's *Ordinance 2000-1* for vegetation management.

LOCATION OF HAZARD: 2945 VISTA DEL RIO

PLEASE SEE REVERSE SIDE OF NOTICE FOR INSTRUCTION FOR ABATEMENT

(Visit www.ncfire.org to view Ordinance 2000-1 in its entirety).

THIS IS CONSIDERED SECOND NOTICE to abate the aforementioned fire hazard(s) on your property. **Hazard abatement must be accomplished within 10 days of this notice.** Properties that have not been cleared or do not comply with the requirements within 10 days will be subject to the district's *Forced Abatement Process*. Property owners are strongly urged to arrange for the clearing of their own parcels, as the above requirements are strictly enforced. **NOTICE HAS BEEN SENT TO THE PROPERTY OWNER OF RECORD AND/OR POSTED ON YOUR PROPERTY ADVISING OF THE NEED TO ABATE FIRE HAZARDS BY THE POSTED DEADLINE. YOU ARE RESPONSIBLE FOR PAYMENT OF NON-COMPLIANCE REINSPECTION EXPENSES INCURRED BY THE DISTRICT.**

DATE	DESCRIPTION	TOTAL
9/3/2021	Non-Compliance Weed Abatement Reinspection	\$364.50

Should you choose not to abate the above hazard, nor make an appeal, the fire chief is authorized to hire a contractor to abate the hazard. The cost of abatement and a \$774.50 administrative fee for each parcel will be assessed to your property. If payment is not received from you, these charges will be placed on the parcel by the County Auditor and collected at the time and in the manner of ordinary property taxes.

If you do not own this property, have already cleared this property, feel you have received this notice in error, or wish to schedule an on-site meeting, please contact the Fire Prevention Bureau at (760) 723-2010 as soon as possible. Additionally, should you disagree with the determination that a hazard exists, you may request an administrative review with the Fire Marshal. Please include your property address and the inspector listed at the bottom of this notice with all inquiries.

Sincerely,
Lars Beeghley, NCFPD

WARNING – ENVIRONMENTALLY PROTECTED PLANTS OR ANIMAL SPECIES

Clearing of vegetation as required by this letter that contains threatened or endangered species is subject to the Memorandum of Understanding (MOU) with the U.S. Fish and Wildlife Service (USFWS) and California Department of Fish and Game (CDFG). Deliberate take or clearing or removal beyond that specifically allowed by this notice and the MOU is not authorized and may be in violation of the State and Federal Endangered Species Act. Please contact the fire district with questions about compliance with the MOU and this notice. You should also contact USFWS at (760) 431-9440 or CDFG (858) 467-4201 if you have been notified that you have a threatened or endangered species on your property.



North County Fire Protection District

330 South Main Avenue • Fallbrook • California 92028
Tel (760) 723-2010 • Fax (760) 723-2045

Board of Directors

Cindy Acosta
Jeffery Eghan
David Kennedy
Kenneth E. Munson
John Van Doorn

Fire Chief

Stephen J. Abbott

NOTICE TO ABATE HAZARD

NOTE: THIS IS NOT A PERMIT TO GRADE YOUR PROPERTY

Date: 7/20/2021

Dear: LISAK AMBER N
2945 VISTA DEL RIO
FALLBROOK CA 92028

Parcel: APN 1026103000

San Diego County Property records show you as owner of the parcel listed above. A recent survey determined that fire hazard(s) exist on your property as defined in North County Fire Protection District's *Ordinance 2000-1* for vegetation management. The fire district's vegetation management program has proven effective in mitigating the spread of vegetation fires and has played a part in keeping the destruction from these fires to a minimum. By this notice, we are requiring owners within the fire district to ensure their property meets these fire safety requirements at all times; doing so will reduce the loss of life and property from vegetation fire. *Please note: Some properties may require hazard abatement more than one time each year.*

LOCATION OF HAZARD: 2945 VISTA DEL RIO

PLEASE SEE REVERSE SIDE OF NOTICE FOR INSTRUCTION FOR ABATEMENT

(Visit www.ncfire.org to view *Ordinance 2000-1* in its entirety).

THIS IS CONSIDERED NOTICE to abate the aforementioned fire hazard(s) on your property in accordance with district *Ordinance 2000-1*. **Hazard abatement must be accomplished within 20 days of this notice.** Properties that have not been cleared or do not comply with the requirements of *Ordinance 2000-1* within 20 days will be subject to the district's *Forced Abatement Process*. Property owners are strongly urged to arrange for the clearing of their own parcels, as the above requirements are strictly enforced. If your property is forcibly abated, the cost will be much higher than if you choose to abate the property yourself or commercially.

If you do not own this property, have already cleared this property, feel you have received this notice in error, or wish to schedule an on-site meeting, please contact the Fire Prevention Bureau at (760) 723-2010 as soon as possible. Additionally, should you disagree with the determination that a hazard exists, you may request an administrative review with the Fire Marshal. Please include your property address and the inspector listed at the bottom of this notice with all inquiries. A \$ 364.50 Noncompliance fee may be assessed if the work is not completed within the 20-day notice time frame.

Sincerely,

Dominic Fieri, Fire Marshal
North County Fire Protection District

WARNING – ENVIRONMENTALLY PROTECTED PLANTS OR ANIMAL SPECIES

Clearing of vegetation as required by this letter that contains threatened or endangered species is subject to the Memorandum of Understanding (MOU) with the U.S. Fish and Wildlife Service (USFWS) and California Department of Fish and Game (CDFG). Deliberate take or clearing or removal beyond that specifically allowed by this notice and the MOU is not authorized and may be in violation of the State and Federal Endangered Species Act. Please contact the fire district with questions about compliance with the MOU and this notice. You should also contact USFWS at (760) 431-9440 or CDFG (858) 467-4201 if you have been notified that you have a threatened or endangered species on your property.



1026103000 | 2945 VISTA DEL RIO

INSPECTOR	Lars Beechley
STATUS	Posted
1ST INSPECTION	7/12/2021
2ND INSPECTION	8/20/2021
FINAL INSPECTION	9/21/2021
POSTED	10/1/2021
ABATED	
HAZARD:	Weeds/Annual Grasses

[Zoom to](#) [Edit](#) [Get Directions](#)
[Show Related Records](#)

Reg...
ard Meeting for May











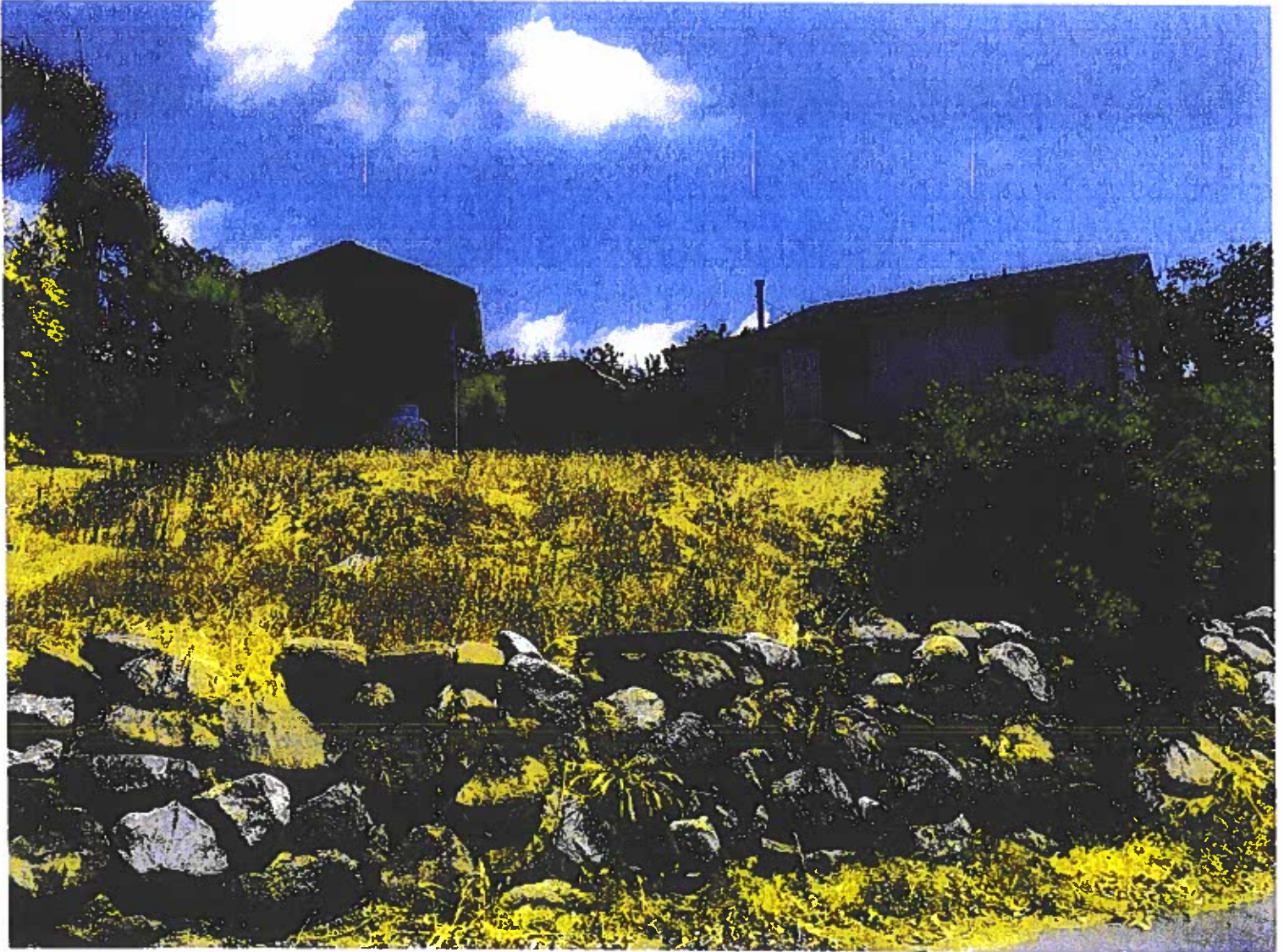



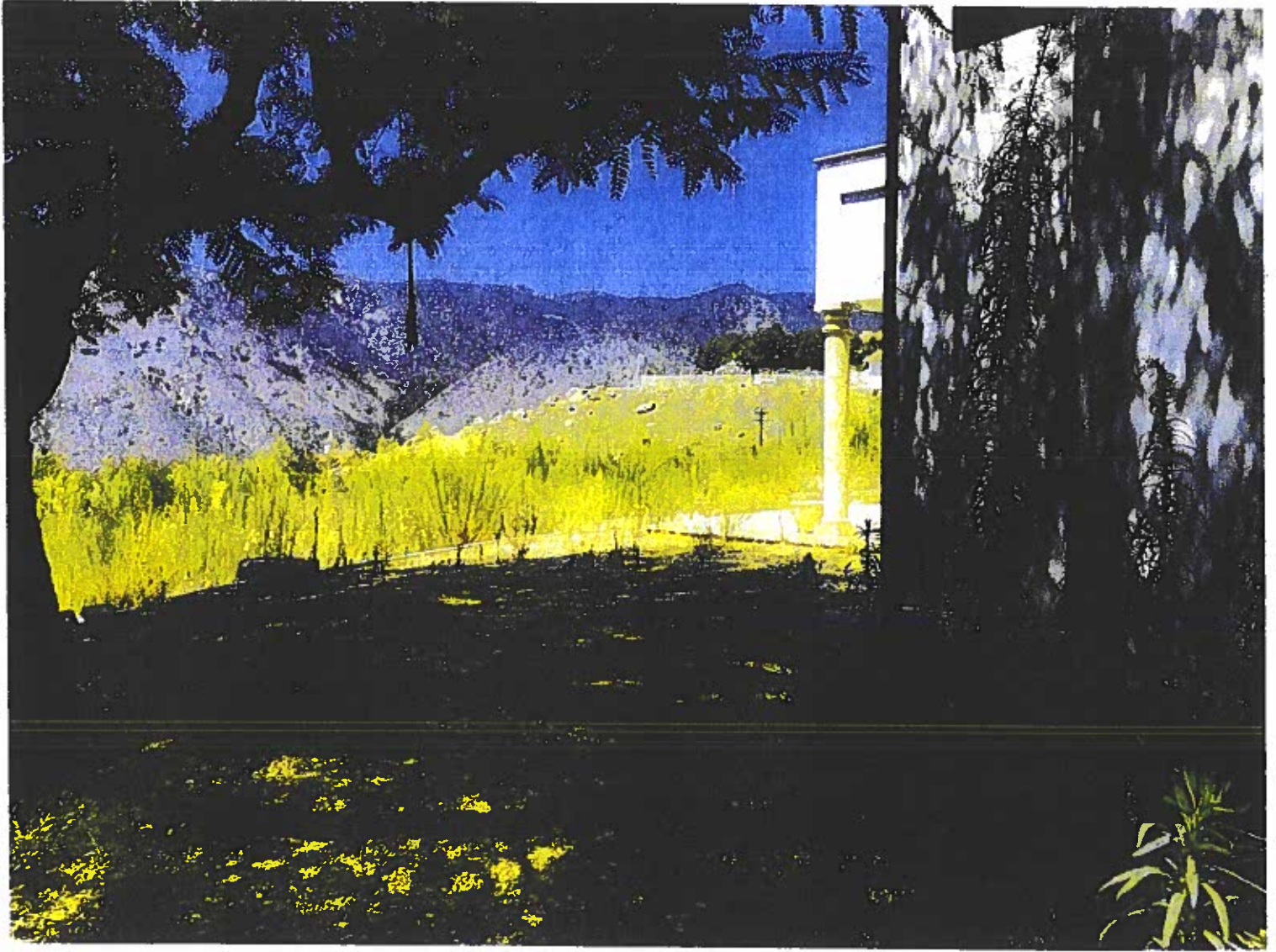

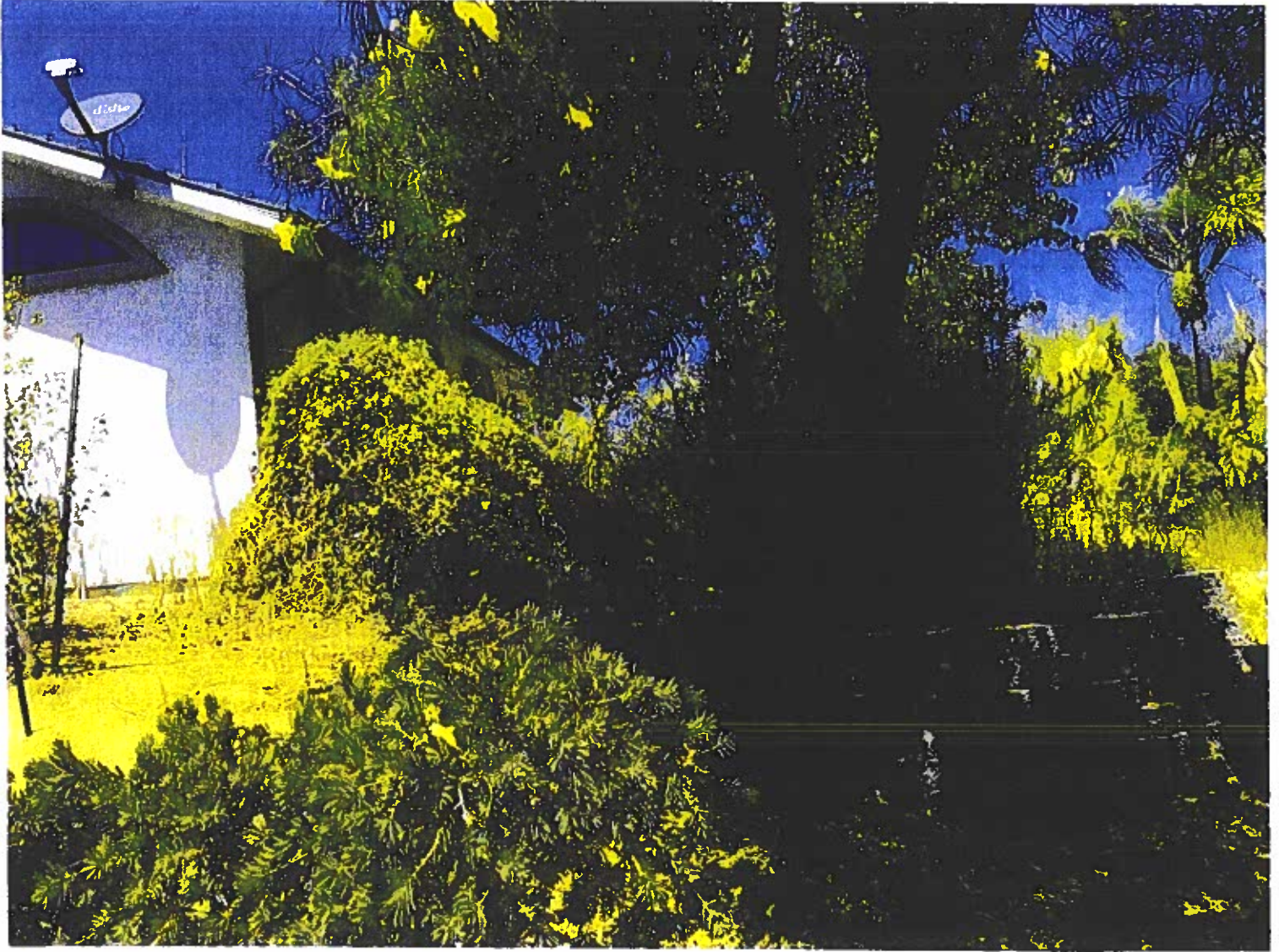





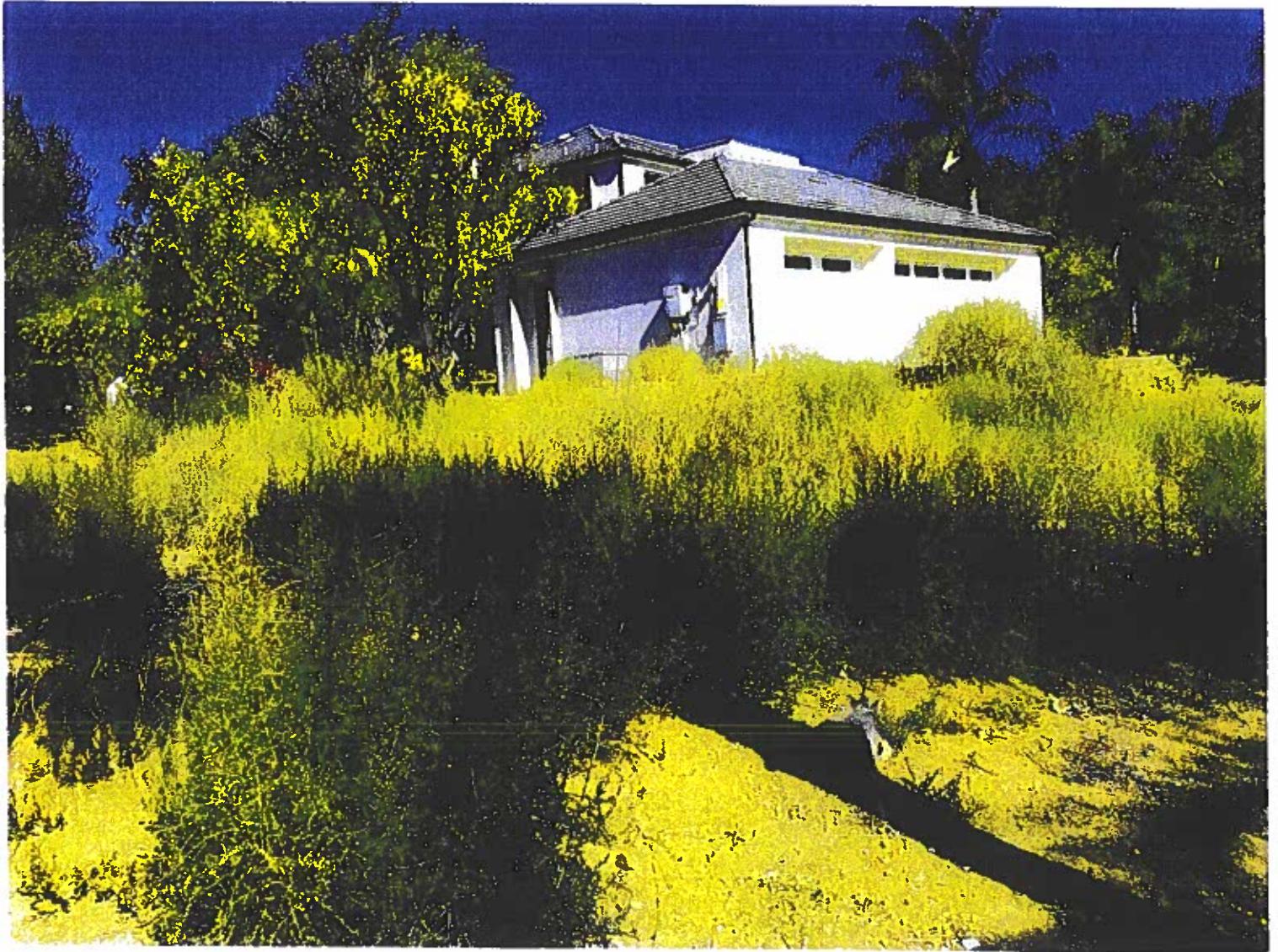



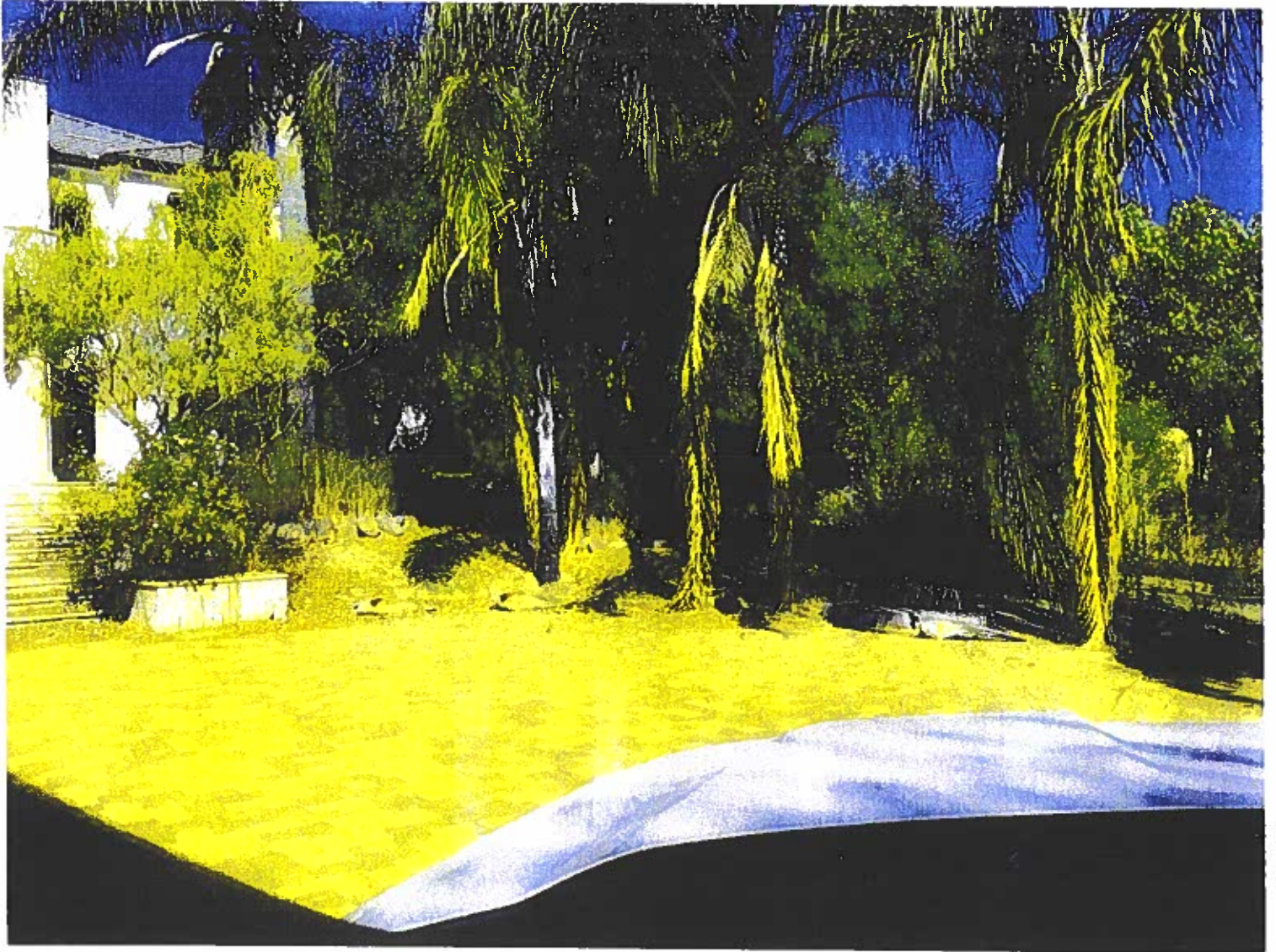



NORTH COUNTY FIRE PROTECTION DISTRICT
 330 South Main Ave. Fallbrook, CA 92028
 Prevention Division

FINAL NOTICE - AFTER FORCED ABATEMENT

05 17 2022

Craig Roalf
 3184 Airway Avenue #K
 Costa Mesa, CA 92626

APN: 1242012900

DATE	AMOUNT	UNITS	DESCRIPTION	TOTAL
11 6 2021	\$756.00	1	Forced Weed Abatement - Admin Fee	\$ 756.00
12 16 2021	\$5,000.00	1	Abatement Work	\$ 5,000.00
12 16 2021	\$8,000.00	1	Abatement Work	\$ 8,000.00
				\$ -
				\$ -
				\$ -
				\$ -
				\$ -
*TOTAL:				\$ 13,756.00

*Note: The non-compliance weed abatement reinspections have already been submitted to a third party cost recovery organization and are not included in this amount.

FINAL NOTICE - AFTER FORCED ABATEMENT

Your cooperation is expected. Failure to pay or correct by **June 28, 2022** will make you liable to the penalties provided by law and subject to forced abatement procedures in accordance with the Consolidated San Diego County Fire Code, Division II, Appendix II-A and NCFPD Ordinance 2000-01.

California Tree Service, Inc

P.O. Box 2019
San Marcos, CA 92079-2019

Invoice

Date	Invoice #
12/30/2021	Roalf-21-1

Bill To

**North County Fire
Protection District
330 Main Ave
Fallbrook, CA 92028**

Ship To
2205 Dos Lomas Fallbrook, CA 92028 Parcel #124-201-29-00

P.O. No.	Terms	Due Date	Job #
M-516	Due on receipt	12/30/2021	

Quantity	Description	Rate	Serviced	Class	Amount
	Day Rate - Mulcher for tree limbs - 4 days 40 hours @ \$125.00/per hour 12/8/21, 12/10/21, 12/13/21, 12/15/21, 12/16/21	5,000.00			5,000.00
	Day rate - Labor for cutting trees - 4 days 4 men, 40 hours @ \$50.00/per hour 12/8/21, 12/10/21, 12/13/21, 12/15/21, 12/16/21	8,000.00			8,000.00

Total		\$13,000.00
Payments/Credits		\$0.00
Balance Due		\$13,000.00

Tax ID#33-0590043

Phone #	Fax #	E-mail	Web Site
760-510-8100	760-746-2867	caltree222@yahoo.com	www.caltrceservice.com

California Tree Service, Inc
P.O. Box 2019
San Marcos, CA 92079-2019



RECEIVED
FEB 19 2022

EN To
Craig Roalf
3184 Airway Avenue #K
Costa Mesa, CA 92626

NIXIE 918 FE 1 8003 16/77

RETURN TO SENDER
ATTEMPTED - NOT KNOWN
UNABLE TO FORWARD

ANK
92626946 9278942
SC: 92079201919 *0600-00003-12-18
7020 3160 0003 2375 2360

CERTIFIED MAIL



California Tree Service, Inc
P.O. Box 2019
San Marcos, CA 92079-2019

NL 2/16

EN To
Craig Roalf
3184 Airway Avenue #K
Costa Mesa, CA 92626



NIXIE 911 FE 1 8002 04/22

RETURN TO SENDER
ATTEMPTED - NOT KNOWN
UNABLE TO FORWARD

ANK
92626946 9278942
SC: 92079201919 *1504-08600-19-39

SAN DIEGO CA 920
5

California Tree Service, Inc
P.O. Box 2019
San Marcos, CA 92079-2019

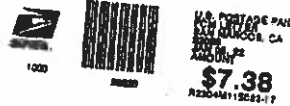

7020 3160 0003 5621 0341

EN To
Craig Roalf
3184 Airway Avenue #K
Costa Mesa, CA 92626

NIXIE 918 FE 1 8001 04/22

RETURN TO SENDER
ATTEMPTED - NOT KNOWN
UNABLE TO FORWARD

ANK
92626946 9278942
SC: 92079201919 *0600-02324-06-17
7020 3160 0003 5621 0341



North County Fire Protection District

330 South Main Avenue • Fallbrook • California 92028
Tel. (760) 723-2010 • Fax (760) 723-2045

Board of Directors
Cindy Acosta
Jeffery Eghan
David Kennedy
Kenneth E. Munson
John Van Doorn

Fire Chief
Keith McReynolds

NOTICE OF PENDING FORCED ABATEMENT AND DUE BILL

NOTE: THIS IS NOT A NOTICE TO GRADE YOUR PROPERTY

Dear: ROALF CRAIG R

Date: 10/27/2021

Parcel: 1242012900

San Diego County Property records show you as owner of the parcel number listed above. A series of recent inspections determined that fire hazard(s) exist on your property as defined in North County Fire Protection District's *Ordinance 2000-01* for abatement of public nuisances. Visit www.ncfire.org to view Ordinance 2000-01 in its entirety

LOCATION OF HAZARD: 2205 DOS LOMAS

INSTRUCTION FOR ABATEMENT: PLEASE SEE REVERSE SIDE OF NOTICE

AT LEAST TWO SEPARATE NOTICES HAVE BEEN SENT TO THE PROPERTY OWNER OF RECORD AND/OR POSTED ON YOUR PROPERTY ADVISING OF THE NEED TO ABATE FIRE HAZARDS BY THE POSTED DEADLINE. AS A RESULT OF FAILURE TO COMPLY WITH THESE NOTICES, THIS PROPERTY IS NOW SCHEDULED FOR FORCED ABATEMENT OF THESE HAZARDS. ABATEMENT WILL OCCUR ON OR AFTER TEN (10) DAYS FROM THE DATE OF THIS NOTICE. AT THIS TIME, YOU ARE RESPONSIBLE FOR PAYMENT OF NON-COMPLIANCE INSPECTION EXPENSES INCURRED BY THE DISTRICT AS WELL AS ASSOCIATED ADMINISTRATIVE CHARGES.

DATE	DESCRIPTION	TOTAL
11/6/2021	Non-Compliance Weed Abatement Reinspection	\$364.50
11/6/2021	Forced Weed Abatement Administrative Fee	\$774.50

If payment is not received from you, these inspection and administrative charges will be placed on the parcel by the County Auditor and collected at the time and in the manner of ordinary property taxes. Additionally, you will also be responsible for forced abatement charges incurred by the Fire District to abate the fire hazards present on your property.

If you do not own this property, have already cleared this property, feel you have received this notice in error, or wish to schedule an on-site meeting, please contact the Fire Prevention Bureau at 760-723-2010 as soon as possible. Additionally, should you disagree with the determination that a hazard exists, you may request an administrative review with the Fire Marshal.

Sincerely,

Stephen Abbott, Fire Chief

WARNING – ENVIRONMENTALLY PROTECTED PLANTS OR ANIMAL SPECIES

Clearing of vegetation as required by this letter that contains threatened or endangered species is subject to the Memorandum of Understanding (MOU) with the U.S. Fish and Wildlife Service (USFWS) and California Department of Fish and Game (CDFG). Deliberate take or clearing or removal beyond that specifically allowed by this notice and the MOU is not authorized and may be in violation of the State and Federal Endangered Species Act. Please contact the fire district with questions about compliance with the MOU and this notice. You should also contact USFWS at (760) 431-9440 or CDFG (858) 467-4201 if you have been notified that you have a threatened or endangered species on your property.



North County Fire Protection District

330 South Main Avenue • Fallbrook • California 92028
Tel (760) 723-2010 • Fax (760) 723-2045

Board of Directors
Cindy Acosta
Jeffery Egkan
David Kennedy
Kenneth E. Munson
John Van Doorn

Fire Chief
Keith McReynolds

NOTICE TO ABATE HAZARD – FINAL NOTICE

NOTE: THIS IS NOT A NOTICE TO GRADE YOUR PROPERTY

Date: 8/31/2021

Dear: ROALF CRAIG R
3184 AIRWAY AVE #K
COSTA MESA CA 92626

Parcel: 1242012900

San Diego County Property records show you as owner of the parcel number listed above. A recent survey determined that fire hazard(s) exist on your property as defined in North County Fire Protection District's *Ordinance 2000-1* for vegetation management.

LOCATION OF HAZARD: 2205 DOS LOMAS

PLEASE SEE REVERSE SIDE OF NOTICE FOR INSTRUCTION FOR ABATEMENT

(Visit www.ncfire.org to view Ordinance 2000-1 in its entirety).

THIS IS CONSIDERED FINAL NOTICE to abate the aforementioned fire hazard(s) on your property. **Hazard abatement must be accomplished within 10 days of this notice.** Properties that have not been cleared or do not comply with the requirements within 10 days will be subject to the district's *Forced Abatement Process*. Property owners are strongly urged to arrange for the clearing of their own parcels, as the above requirements are strictly enforced. **NOTICE HAS BEEN SENT TO THE PROPERTY OWNER OF RECORD AND/OR POSTED ON YOUR PROPERTY ADVISING OF THE NEED TO ABATE FIRE HAZARDS BY THE POSTED DEADLINE. YOU ARE RESPONSIBLE FOR PAYMENT OF NON-COMPLIANCE REINSPECTION EXPENSES INCURRED BY THE DISTRICT.**

DATE	DESCRIPTION	TOTAL
9/10/2021	Non-Compliance Weed Abatement Reinspection	\$364.50

Should you choose not to abate the above hazard, nor make an appeal, the fire chief is authorized to hire a contractor to abate the hazard. The cost of abatement and a \$774.50 administrative fee for each parcel will be assessed to your property. If payment is not received from you, these charges will be placed on the parcel by the County Auditor and collected at the time and in the manner of ordinary property taxes.

If you do not own this property, have already cleared this property, feel you have received this notice in error, or wish to schedule an on-site meeting, please contact the Fire Prevention Bureau at (760) 723-2010 as soon as possible. Additionally, should you disagree with the determination that a hazard exists, you may request an administrative review with the Fire Marshal. Please include your property address and the inspector listed at the bottom of this notice with all inquiries.

Sincerely,
Lars Beeghley, NCFPD

WARNING – ENVIRONMENTALLY PROTECTED PLANTS OR ANIMAL SPECIES

Clearing of vegetation as required by this letter that contains threatened or endangered species is subject to the Memorandum of Understanding (MOU) with the U.S. Fish and Wildlife Service (USFWS) and California Department of Fish and Game (CDFG). Deliberate take or clearing or removal beyond that specifically allowed by this notice and the MOU is not authorized and may be in violation of the State and Federal Endangered Species Act. Please contact the fire district with questions about compliance with the MOU and this notice. You should also contact USFWS at (760) 431-9440 or CDFG (858) 467-4201 if you have been notified that you have a threatened or endangered species on your property.



North County Fire Protection District

330 South Main Avenue • Fallbrook • California 92028
Tel (760) 723-2010 • Fax (760) 723-2045

Board of Directors
Cindy Acosta
Jeffery Egkan
David Kennedy
Kenneth E. Munson
John Van Doorn

Fire Chief
Keith McReynolds

NOTICE TO ABATE HAZARD – SECOND NOTICE

NOTE: THIS IS NOT A NOTICE TO GRADE YOUR PROPERTY

Date: 8/17/2021

Dear: ROALF CRAIG R
3184 AIRWAY AVE #K
COSTA MESA CA 92626

Parcel: 1242012900

San Diego County Property records show you as owner of the parcel number listed above. A recent survey determined that fire hazard(s) exist on your property as defined in North County Fire Protection District's *Ordinance 2000-1* for vegetation management.

LOCATION OF HAZARD: 2205 DOS LOMAS

PLEASE SEE REVERSE SIDE OF NOTICE FOR INSTRUCTION FOR ABATEMENT

(Visit www.ncfire.org to view Ordinance 2000-1 in its entirety).

THIS IS CONSIDERED SECOND NOTICE to abate the aforementioned fire hazard(s) on your property. **Hazard abatement must be accomplished within 10 days of this notice.** Properties that have not been cleared or do not comply with the requirements within 10 days will be subject to the district's *Forced Abatement Process*. Property owners are strongly urged to arrange for the clearing of their own parcels, as the above requirements are strictly enforced. **NOTICE HAS BEEN SENT TO THE PROPERTY OWNER OF RECORD AND/OR POSTED ON YOUR PROPERTY ADVISING OF THE NEED TO ABATE FIRE HAZARDS BY THE POSTED DEADLINE. YOU ARE RESPONSIBLE FOR PAYMENT OF NON-COMPLIANCE REINSPECTION EXPENSES INCURRED BY THE DISTRICT.**

DATE	DESCRIPTION	TOTAL
8/27/2021	Non-Compliance Weed Abatement Reinspection	\$364.50

Should you choose not to abate the above hazard, nor make an appeal, the fire chief is authorized to hire a contractor to abate the hazard. The cost of abatement and a \$774.50 administrative fee for each parcel will be assessed to your property. If payment is not received from you, these charges will be placed on the parcel by the County Auditor and collected at the time and in the manner of ordinary property taxes.

If you do not own this property, have already cleared this property, feel you have received this notice in error, or wish to schedule an on-site meeting, please contact the Fire Prevention Bureau at (760) 723-2010 as soon as possible. Additionally, should you disagree with the determination that a hazard exists, you may request an administrative review with the Fire Marshal. Please include your property address and the inspector listed at the bottom of this notice with all inquiries.

Sincerely,
Lars Beeghley, NCFPD

WARNING – ENVIRONMENTALLY PROTECTED PLANTS OR ANIMAL SPECIES

Clearing of vegetation as required by this letter that contains threatened or endangered species is subject to the Memorandum of Understanding (MOU) with the U.S. Fish and Wildlife Service (USFWS) and California Department of Fish and Game (CDFG). Deliberate take or clearing or removal beyond that specifically allowed by this notice and the MOU is not authorized and may be in violation of the State and Federal Endangered Species Act. Please contact the fire district with questions about compliance with the MOU and this notice. You should also contact USFWS at (760) 431-9440 or CDFG (858) 467-4201 if you have been notified that you have a threatened or endangered species on your property.



North County Fire Protection District

330 South Main Avenue • Fallbrook • California 92028
Tel. (760) 723-2010 • Fax (760) 723-2045

Board of Directors

Cindy Acosta
Jeffery Eghan
David Kennedy
Kenneth E. Munson
John Van Doorn

Fire Chief

Stephen J. Abbott

NOTICE TO ABATE HAZARD

NOTE: THIS IS NOT A PERMIT TO GRADE YOUR PROPERTY

Date: 7/7/2021

Dear: ROALF CRAIG R
3184 AIRWAY AVE #K
COSTA MESA CA 92626

Parcel: APN 1242012900

San Diego County Property records show you as owner of the parcel listed above. A recent survey determined that fire hazard(s) exist on your property as defined in North County Fire Protection District's *Ordinance 2000-1* for vegetation management. The fire district's vegetation management program has proven effective in mitigating the spread of vegetation fires and has played a part in keeping the destruction from these fires to a minimum. By this notice, we are requiring owners within the fire district to ensure their property meets these fire safety requirements at all times; doing so will reduce the loss of life and property from vegetation fire. *Please note: Some properties may require hazard abatement more than one time each year.*

LOCATION OF HAZARD: 2205 DOS LOMAS

PLEASE SEE REVERSE SIDE OF NOTICE FOR INSTRUCTION FOR ABATEMENT

(Visit www.ncfire.org to view *Ordinance 2000-1* in its entirety).

THIS IS CONSIDERED NOTICE to abate the aforementioned fire hazard(s) on your property in accordance with district *Ordinance 2000-1*. Hazard abatement must be accomplished within 20 days of this notice. Properties that have not been cleared or do not comply with the requirements of *Ordinance 2000-1* within 20 days will be subject to the district's *Forced Abatement Process*. Property owners are strongly urged to arrange for the clearing of their own parcels, as the above requirements are strictly enforced. If your property is forcibly abated, the cost will be much higher than if you choose to abate the property yourself or commercially.

If you do not own this property, have already cleared this property, feel you have received this notice in error, or wish to schedule an on-site meeting, please contact the Fire Prevention Bureau at (760) 723-2010 as soon as possible. Additionally, should you disagree with the determination that a hazard exists, you may request an administrative review with the Fire Marshal. Please include your property address and the inspector listed at the bottom of this notice with all inquiries. A \$ 364.50 Noncompliance fee may be assessed if the work is not completed within the 20-day notice time frame.

Sincerely,

Dominic Fieri, Fire Marshal
North County Fire Protection District

WARNING – ENVIRONMENTALLY PROTECTED PLANTS OR ANIMAL SPECIES

Clearing of vegetation as required by this letter that contains threatened or endangered species is subject to the Memorandum of Understanding (MOU) with the U.S. Fish and Wildlife Service (USFWS) and California Department of Fish and Game (CDFG). Deliberate take or clearing or removal beyond that specifically allowed by this notice and the MOU is not authorized and may be in violation of the State and Federal Endangered Species Act. Please contact the fire district with questions about compliance with the MOU and this notice. You should also contact USFWS at (760) 431-9440 or CDFG (858) 467-4201 if you have been notified that you have a threatened or endangered species on your property.





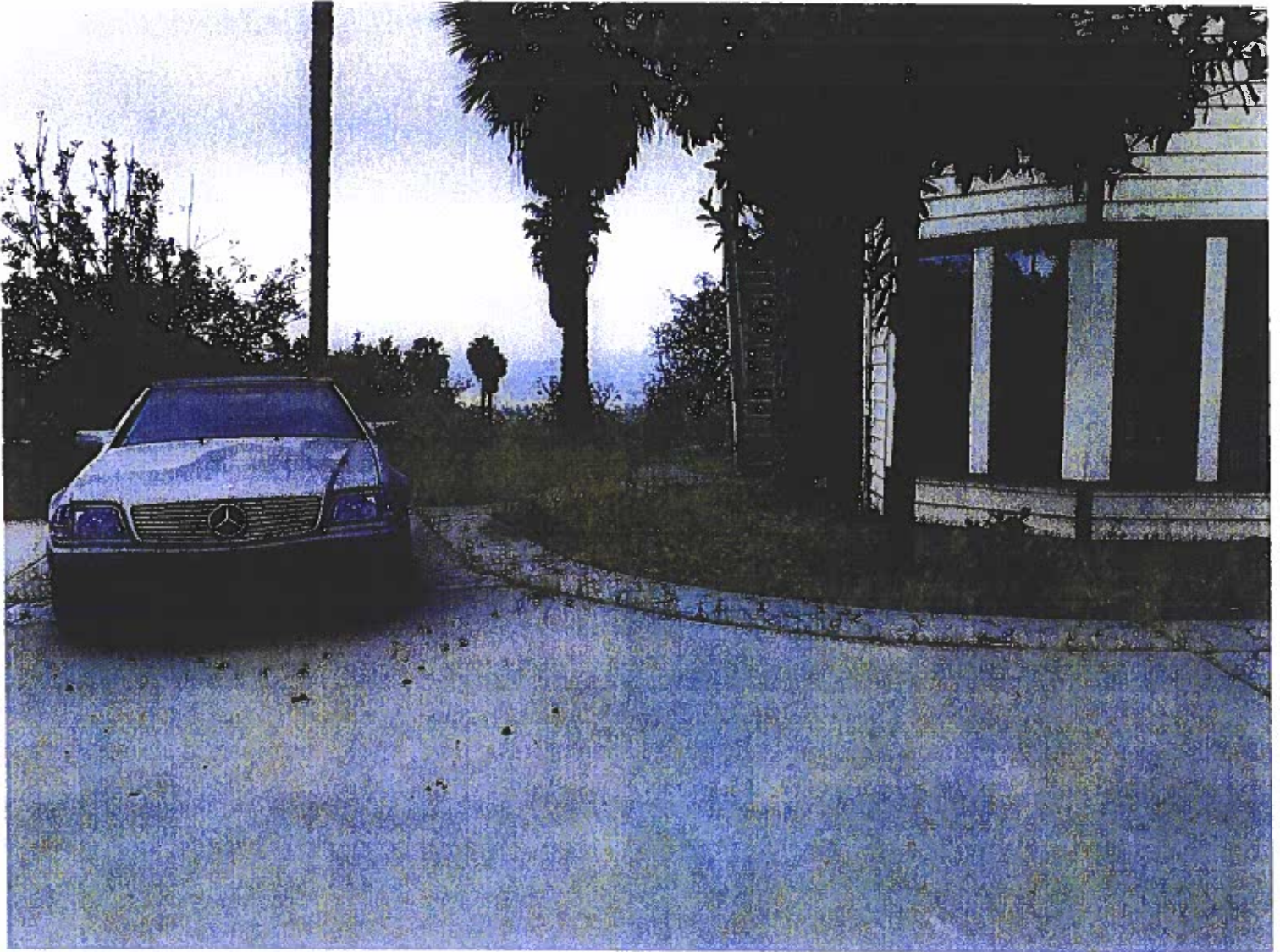



















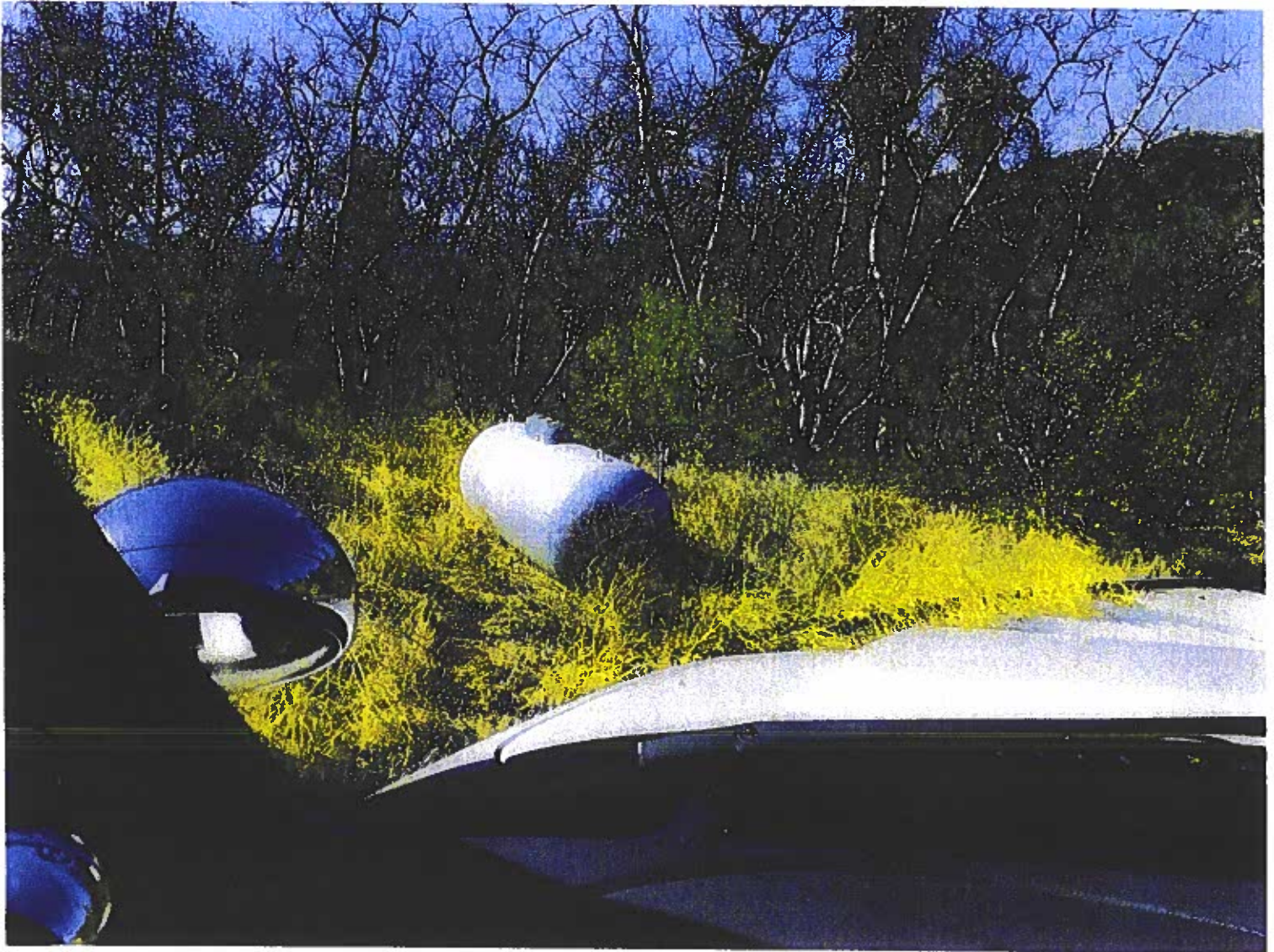



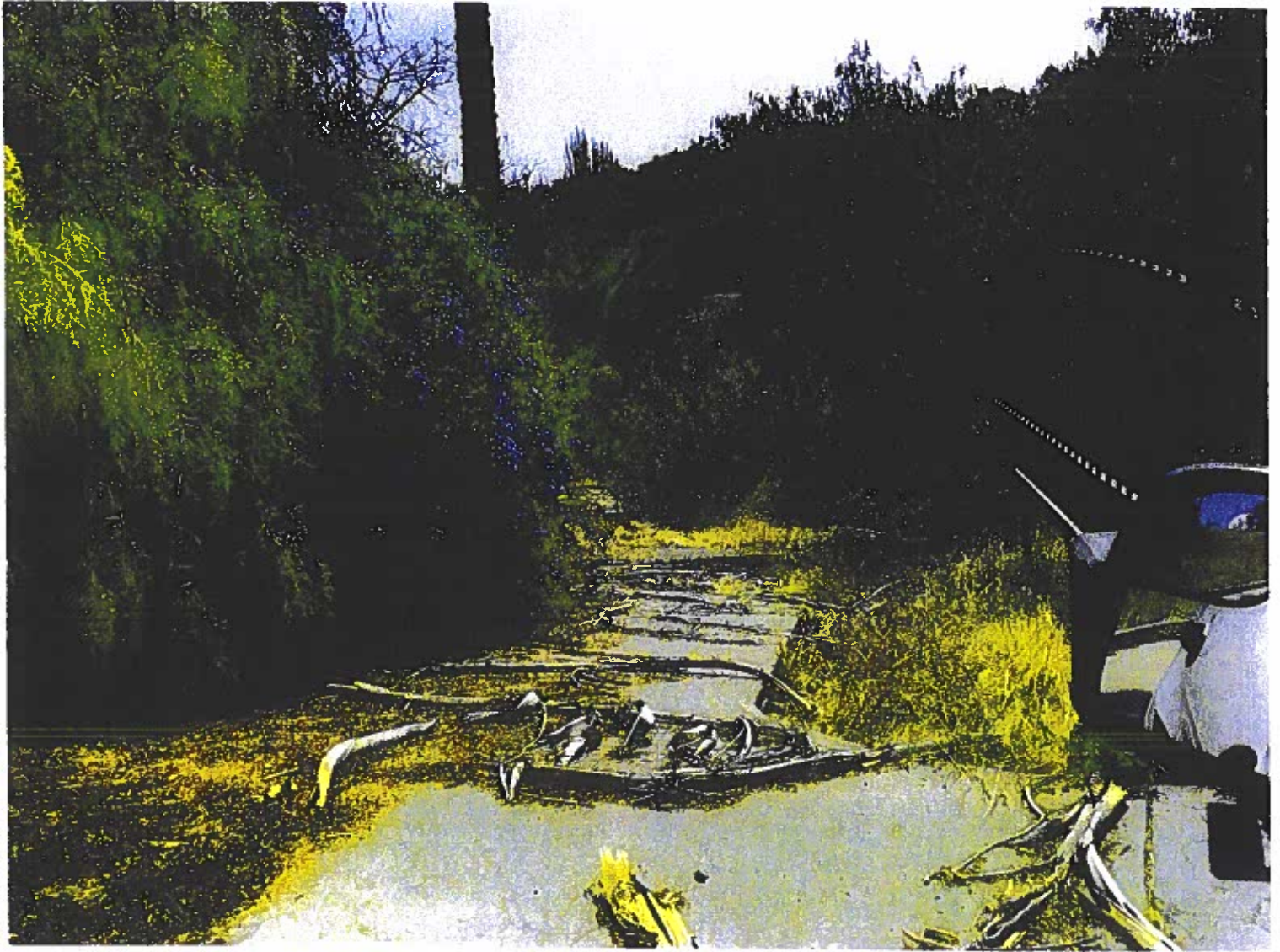





CALIFORNIA TREE SERVICE, INC
 P.O. Box 2019
 San Marcos, CA. 92079 - 2019
 Phone: (760) 510-8100 • Fax: (760) 746-2867
 Email: office@caltreeservice.com

ARBOR SERVICE AGREEMENT

Tuesday, October 26, 2021

This proposal will be honored for up to thirty (30) days.

JOB ID: PROPOSAL # JOB PO#

PROJECT NAME:
 PROJECT ADDRESS: **2205 Dos Lomas, Fallbrook Ca**

CONTACT: **Lars Beeghley**

PHONE: (760) 723-2012
 FAX: (760) 723-2072

MOBILE:

lbeeghley@ncfire.org

QTY	TYPE	DESCRIPTION	UNIT	TOTAL
				\$ -
		Mulcher for all the tree limbs		\$ 5,000.00
		\$125 per hour-40hours		\$ -
				\$ -
		Labor for cutting trees		\$ -
		4 men at \$50 per hour-40hours		\$ 8,000.00
				\$ -
				\$ -
				\$ -
				\$ -
				\$ -
		CTS will chip all material back onsite		\$ -
				\$ -
		Terms and conditions apply per agreement with North County Fire		\$ -
				\$ -
		<i>Net 30 Days</i>		
		<i>A 1.5% late fee will be charged on all past due accounts.</i>		
		GRAND TOTAL		\$ 13,000.00

CALIFORNIA TREE SERVICE, INC.

CUSTOMER

Matt Preston

PRINT NAME

ICEPT + M. PRESTON

PRINT NAME

Arborist/Estimator

TITLE

FING CHIEF / CEO

TITLE

DATE

11-10-2021

DATE



CALIFORNIA TREE SERVICE, INC
 P.O. Box 2019
 San Marcos, CA. 92079 - 2019
 Phone: (760) 510-8100 • Fax: (760) 746-2867
 Email: office@caltreeservice.com

ARBOR SERVICE AGREEMENT

Tuesday, October 26, 2021

This proposal will be honored for up to thirty (30) days.

JOB ID: PROPOSAL # JOB PO#

PROJECT NAME:
 PROJECT ADDRESS: **2945 Vista Del Rio, Fallbrook Ca**

CONTACT: **Lars Beeghley**

PHONE: **(760) 723-2012**

FAX: **(760) 723-2072**

MOBILE:

lbeeghley@ncfire.org

QTY	TYPE	DESCRIPTION	UNIT	TOTAL
				\$ -
		Mulcher for all the tree limbs		\$ 4,000.00
		\$125 per hour-32hours		\$ -
				\$ -
		Labor for cutting trees		\$ -
		4 men at \$50 per hour-32hours		\$ 6,400.00
				\$ -
				\$ -
				\$ -
				\$ -
				\$ -
				\$ -
		CTS will chip all material back onsite		\$ -
				\$ -
		Terms and conditions apply per agreement with North County Fire		\$ -
				\$ -
		<i>Net 30 Days</i>		
		<i>A 1.5% late fee will be charged on all past due accounts.</i>		
		GRAND TOTAL	\$	10,400.00

 CALIFORNIA TREE SERVICE, INC.

 CUSTOMER

Matt Preston

PRINT NAME

KENT M. REYNOLDS *Lars Beeghley*

PRINT NAME

Arborist/Estimator

TITLE

FINC MGT-CEO

TITLE

 DATE

11-10-2021

DATE

CALIFORNIA TREE	California Tree Service	0000000000045493	5/17/2022	065012		
0000000000045492	LISAK-21-1	5/17/2022	\$10,400.00	\$10,400.00	\$0.00	\$10,400.00
0000000000045493	ROALF-21-1	5/17/2022	\$13,000.00	\$13,000.00	\$0.00	\$13,000.00

\$23,400.00



NORTH COUNTY FIRE PROTECTION DISTRICT

330 S. Main Avenue
Fallbrook, CA 92028
Phone (760) 723-2008



90-4075/1222

DATE

065012

AMOUNT

5/17/2022

\$23,400.00

Twenty Three Thousand Four Hundred Dollars and 00 Cents

PAY
TO THE
ORDER
OF:

California Tree Service
P.O. BOX 2019
SAN MARCOS CA 92079-2019



AUTHORIZED SIGNATURE

⑈065012⑈ ⑆⑆2224075⑆⑆ 007508875⑈

NORTH COUNTY FIRE PROTECTION DISTRICT

065012

CALIFORNIA TREE	California Tree Service	0000000000045493	5/17/2022	065012		
0000000000045492	LISAK-21-1	5/17/2022	\$10,400.00	\$10,400.00	\$0.00	\$10,400.00
0000000000045493	ROALF-21-1	5/17/2022	\$13,000.00	\$13,000.00	\$0.00	\$13,000.00

\$23,400.00

NORTH COUNTY FIRE PROTECTION DISTRICT

330 S. Main Avenue • Fallbrook, California 92028-2938 • Phone: (760) 723-2005 • Fax: (760) 723-2072 • Web: www.ncfire.org

BOARD OF DIRECTORS

RUTH HARRIS
BOB HOFFMAN
FRED LUEVANO
KENNETH E. MUNSON
JOHN VAN DOORN

STEPHEN J. ABBOTT - Fire Chief/CEO - sabbott@ncfire.org
ROBERT H. JAMES - District Counsel - roberthjameslaw@gmail.com
LOREN A. STEPHEN-PORTER - Executive Assistant/Board Secretary - lstephen@ncfire.org

Attachment E

June 28, 2022

County of San Diego
Auditor and Controller
Property Tax Services
5530 Overland Avenue, Suite 410
San Diego, CA 92123

CERTIFICATION OF FIXED CHARGE SPECIAL ASSESSMENTS

This letter is to certify that, according to the records of North County Fire Protection District, all assessments and special taxes are in compliance with Article XIII C and D of the Constitution of the State of California, that the total number of parcels subject to Fixed Charge Special Assessments and the dollar amount by fund for 2019/2020 are as listed below:

Fund Number	Count	Amount
3107-01	2	\$24,912.00

Certified By:

Dominic Fieri
Fire Marshal



PROUDLY SERVING THE COMMUNITIES OF FALLBROOK, BONSALE AND RAINBOW

DUTY ~ INTEGRITY ~ RESPECT

Regular Board Meeting for May 24, 2022

Page - 161

PAGE INTENTIONALLY BLANK



**NORTH COUNTY FIRE
PROTECTION DISTRICT**

FIRE CHIEF / CEO

TO: BOARD OF DIRECTORS
FROM: D/C MACMILLAN AND CHIEF McREYNOLDS
DATE: MAY 24, 2022
SUBJECT: STATION 2 FACILITY MAINTENANCE PROJECT

ACTION AGENDA

RECOMMENDATION:

That the Board authorize Staff to execute a contract with *Reed Family Enterprises Inc.* for the Station 2 Maintenance Project.

BACKGROUND:

In January 2022, a site inspection of Fire Station 2 by Staff revealed multiple structure and grounds issues due to years of deferred maintenance. Several of these issues now present a safety risk for both our employees and the public. The maintenance needs identified were consistent with the 2017 *Jorgensen* Facility Reserve Study the District conducted.

In February 2022, the NCFPD BOD directed Staff to contract with *Ericson-Hall Construction* to develop a Request for Proposal (RFP) for the needed maintenance work at Fire Station 2. As a result of that RFP process, the lowest responsive/responsible bidder was determined to be *Reed Family Enterprises, Inc.*

DISCUSSION:

In collaboration with *Ericson-Hall Construction* job inspectors and managers, Staff created a list of needed maintenance projects at Fire Station 2. These items, which are included in the project scope of work, will provide safety, security, operational and aesthetic enhancements to the station and grounds that are much needed. The scope of the project will include the following:

- Replacement of severely cracked and missing concrete on driveways
- New exterior lighting with dusk-to-dawn sensors
- Replace non-operable damaged electric gate sensors
- Interior/exterior paint
- New apparatus bay doors and controllers
- Visitor parking with signage
- Repair of exterior wood fascia/beams

Station 2 Facility Maintenance Project

May 24, 2022

Page 2 of 2

- Landscaping
- Irrigation
- Additional employee parking

FISCAL ANALYSIS:

Estimate: \$320,000 (includes \$70,000 Allowance)

Bid Proposal Amt: \$353,410

The funding for this project will be allocated in the NCFPD FY 22/23 Budget.

SUMMARY:

This maintenance project will greatly improve the functionality and safety of this Station. These upgrades will minimize the risk of injury through reducing trip hazards, promote property security, provide structural maintenance and enhance aesthetics to a station that will be serving the District for many years to come. Once approved, Staff will execute a contract with *Reed Family Enterprises Inc.* The work is expected to begin in June 2022.



**NORTH COUNTY FIRE
PROTECTION DISTRICT
FIRE CHIEF / CEO**

TO: BOARD OF DIRECTORS
FROM: CHIEF McREYNOLDS
DATE: MAY 24, 2022
SUBJECT: STATION 3 RENOVATION CONSTRUCTION MANAGEMENT

ACTION AGENDA

RECOMMENDATION:

That the Board direct Staff to execute a contract with *Erickson-Hall Construction* for construction management services for the renovation of Fire Station 3.

BACKGROUND:

In January 2022, the NCFPD Board of Directors approved the renovation of Fire Station 3. The Board also directed Staff to hire a construction management company to oversee the renovation of the project using the design-build process.

DISCUSSION:

The District conducted an open Request for Proposal (RFP) process for construction management services. As a result of the RFP process, Staff has determined that *Erikson-Hall Construction* was the lowest most responsive bidder. Their scope of work includes three (3) phases of work:

- Planning: *Request For Statement of Qualifications (RFSQ)/Request for Proposal (RFP) for preparation and selection of design team.*
- Pre-Construction: *Construction management design services.*
- Construction: *Project oversight.*

FISCAL ANALYSIS:

Planning phase services:	\$ 59,180
Preconstruction Phase Services:	\$ 120,560
Construction Phase Services:	\$ 210,600
Reprographic Expense Allowance:	\$ 5,000
Total:	\$ 395,340

Station 3 Renovation Construction Project

May 24, 2022

Page 2 of 2

The District budgeted \$500,000 in the FY 21/22 budget for Fire Station 4 engineering that will not be utilized due to ongoing property easement restrictions. Until the easement issues are resolved, or another site is identified for Fire Station 4, those funds will not be expended. Staff would like to reassign those funds in the FY22/23 budget to fund construction management services for the Fire Station 3 renovation project.

SUMMARY:

Ericson-Hall Construction is a reputable organization with extensive San Diego fire station construction experience. Staff feels they will provide exceptional leadership and project oversight to the Fire Station 3 renovation project. When approved, Staff will execute a contract with *Ericson-Hall Construction* for the services proposed.



**NORTH COUNTY FIRE
PROTECTION DISTRICT
OPERATIONS DIVISION STAFF REPORT**

TO: BOARD OF DIRECTORS
FROM: DEPUTY CHIEF MAHR AND CHIEF MCREYNOLDS
DATE: MAY 24, 2022
SUBJECT: BLS AMBULANCE TRIAL

DISCUSSION AGENDA

BACKGROUND:

During the March 2022 Board meeting, the Board approved the trial of a Basic Life Support (BLS) ambulance staffed with two (2) Single-Role Emergency Medical Technicians (EMT) to the North Zone to assist with ambulance service surge capacity.

DISCUSSION:

The BLS ambulance was placed into service on April 11, 2022, as a 12-hour resource and stationed at Vista Fire Department Station 6. Since that time, thirty days' worth of data has been collected.

From April 11, 2022, to May 11, 2022, the BLS ambulance responded to a total of 188 incidents within the jurisdictions of Vista, Oceanside, Carlsbad and North County Fire. Of those 188 incidents, the ambulance transported 85 times for a daily transport average of 2.70 transports per 12-hour shift. In reviewing the automatic aid given and received data from this same time, the data suggests that the BLS ambulance is having a positive impact by equalizing the aid given and received between the cities of Vista, Carlsbad and Oceanside. The equalization of this aid provides for a more equitable North Zone Boundary Drop Agreement.

FISCAL ANALYSIS:

During the first thirty days of operation the personnel costs for the BLS ambulance were \$23,800. Other operating expenses such as fuel and supplies were approximately \$6000. Based on the information received from the districts third-party billing administrator, the very early estimated ambulance transport revenue from the BLS unit is expected to be approximately \$56,600. Due to the billing company not receiving actual payments for 30 to 60 days from time of billing, the estimate is based upon our current collection rate and payer mix.

Based on these findings, the data suggest that the BLS ambulance is currently operating in financially sustainable manner with potential revenue earnings of \$26,000 for the first month of operation.

SUMMARY:

Preliminary response data is indicating that the BLS ambulance is having a positive impact to the North Zone ambulance delivery system while supporting operating costs through transport revenue. This resource has accomplished its mission to provide the North Zone ambulance delivery system surge capacity, preserving the North Zone ambulance delivery system in its entirety.

DISCUSSION QUESTIONS:

1. Does the Board support the continued deployment of the BLS ambulance resource to the North Zone for the next several months?
2. If so, when would the Board like to have another review of the program?



NORTH COUNTY FIRE PROTECTION DISTRICT

STAFF REPORT

TO: BOARD OF DIRECTORS
FROM: FIM JUUL AND CHIEF McREYNOLDS
DATE: MAY 24, 2022
SUBJECT: DISCUSSION ON PRELIMINARY BUDGET

DISCUSSION AGENDA

BACKGROUND:

Each year the Board of Directors are required to adopt a Preliminary Budget by June 30th and a final budget by October 1st.

DISCUSSION:

The Budget captures the revenue and expenses for each Fiscal Year and references the past year to allow the Board of Directors to analyze how the District is performing. Budgetary numbers provided are estimates since estimated charges and other significant budgetary information will not be available until June. The concept is to have property tax, ambulance and prevention fees to fund personnel, operations, and maintenance (O&M) and designate a percentage to reserves. The intent is for the District to become "cash" based for capital equipment expenditures saving on interest. The remaining revenue accounts would be the source of these monies towards capital expenditures. The goal is to fully fund the future equipment replacement plan.

FISCAL ANALYSIS:

Identified in the attached Balance, Expense Summary and Revenue Documents.

SUMMARY:

The attached documents provide an overview of the Preliminary Budget. Staff will take all recommendations from the Board of Directors to provide a Budget to meet all the needs of the District.

North County Fire

Preliminary Budget Review

FY 2022/23

REVENUE

Funding Source	FY21/22 Budget	YTD thru 04/30/22	FY 22/23 Prelim Budget	Prelim/Final Variance	Notes
Property Tax	\$ 17,069,982	\$ 15,929,191	\$ 17,254,100	184,118	5.0% increase over 20/21 actual
Property Tax (Rainbow)	344,250	344,815	345,400	1,150	4.5% increase over 20/21 actual
TOTAL PROPERTY TAXES	17,414,232	16,274,006	17,599,500	\$ 185,268	
Ambulance Fees	3,100,000	2,340,423	2,465,900	(634,100)	
Prevention Fees	250,000	254,954	218,700	(31,300)	
Tower Lease Agreements	91,045	1,153,004	25,200	(65,845)	
Other Revenue Sources	40,000	231,858	-	(40,000)	
Interest	50,000	29,723	45,000	(5,000)	
Weed Abatement/Mowing Reimbursement	-	13,021	9,000	9,000	
Cost Recovery	50,000	42,043	50,000	-	
Fallbrook Regional Health District	93,000	155,989	82,200	(10,800)	50% Salaries
Community Facilities District (CFD)	165,682	-	175,000	9,318	
Annexation Fees	-	-	-	-	
TOTAL FEES	3,839,727	4,221,015	3,148,400	(768,727)	
Strike Team Reimb - OES	198,126	861,155	-	(198,126)	
Other Reimbursements	40,782	13,869	-	(40,782)	
GEMT - State Supplement	-	-	-	-	
TOTAL REIMBURSEMENTS	238,908	1,722,309	-	(238,908)	
TOTAL GENERAL FUND REVENUE	21,492,867	22,217,330	20,747,900	(822,367)	
Donations & Grants	1,050,000	2,439,337	-	(1,050,000)	
Mitigation Fees & Interest (Fallbrook)	310,000	509,754	541,200	231,200	
Mitigation Fees & Interest (Rainbow)	-	-	-	-	
TOTAL RESTRICTED FUNDS	1,360,000	2,949,091	541,200	(818,800)	
GRAND TOTAL REVENUE	22,852,867	25,166,422	21,289,100	(1,641,167)	

EXPENSE SUMMARY

Account	Description	FY 21/22 Budget	YTD thru 04/30/22	FY 22/23 Prelim Budget	Prelim/Final Variance	Notes
Personnel						
	Salaries	7,656,186	5,942,036	8,178,000	521,814	
	Overtime	1,470,666	1,865,471	1,385,700	(84,966)	
	Other Pay	1,043,900	789,920	963,300	(80,600)	
	Benefits	5,112,425	3,525,213	5,369,100	256,675	
	Workers Comp.	700,000	373,707	659,240	(40,760)	
	TOTAL	\$ 15,983,177	\$ 12,496,346	\$ 16,555,340	572,163	
O & M						
Board Administration	101	516,000	328,835	534,000	18,000	
Administration	102	1,090,162	632,520	1,020,420	(69,742)	
Prevention	103	72,400	13,520	82,800	10,400	
Operations	104	576,155	454,979	392,850	(183,305)	
Emergency Medical	105	528,385	478,658	510,350	(18,035)	
Explorers	106	2,000				
Communications	107	665,800	524,639	711,400	45,600	
Fleet Maintenance	108	398,580	290,840	418,200	19,620	
Training	109	78,000	68,949	79,000	1,000	
	TOTAL	\$ 3,927,482	\$ 2,792,941	\$ 3,749,020	(176,462)	
Contingency		206,582			(206,582)	
Deposit to Reserves		300,000		300,000	-	
Facilities		1,294,390	290,764	4,097,340		
CIP		1,400,239	728,958	3,120,900		
	TOTAL	\$ 3,201,211	\$ -	\$ 7,518,240	(206,582)	
TOTAL GENERAL FUND		\$ 23,111,870	\$ 15,289,287	\$ 27,822,600	4,710,730	

BALANCE

Account	Description	FY 21/22 Budget	YTD thru 04/30/22	FY 22/23 Prelim Budget	Notes
Revenue					
	Property Tax	17,414,232	16,274,006	17,599,500	
	Fees	3,839,727	7,077,973	3,148,400	
	Reimbursements	238,908	1,722,309	-	
	Restricted Funds	1,360,000	2,949,091	541,200	
	Deposit from Reserves			542,000	
	Deposit from Reserves Facility			300,000	
	Deposit from Reserves CIP			745,000	
	One time monies	259,000	-	3,930,000	includes 900K, \$1M tower, \$1.4 CSDA, etc
	Transfer from Rainbow			1,861,500	
	Grand Total Revenue	\$ 23,111,867	\$ 28,023,379	\$ 28,667,600	
Expenses					
	Personnel	15,983,177	12,496,346	16,555,340	
	O&M	3,927,482	2,792,941	3,749,020	
	Contingency	206,582	-	100,000	
	Deposit to Reserves Facility	300,000	-	300,000	
	Deposit to Reserves CIP			745,000	
	Facilities	1,294,390	290,764	4,097,340	
	Capital Improvement Plan	1,400,239	448,105	3,120,900	
	Grand Total Expenses	\$ 23,111,870	\$ 16,028,156	\$ 28,667,600	

PAGE INTENTIONALLY BLANK

ROBERT H. JAMES

ATTORNEY AT LAW

ROBERT H. JAMES, Esq.
roberthjameslaw@gmail.com

3668 KATIE LENDRE DRIVE
FALLBROOK, CALIFORNIA 92028

TELEPHONE
(760) 723-9018

May 1, 2022

**Board of Directors
North County Fire Protection District**

Re: General Counsel Board Report for May 1, 2022

Will Virtual Public Meetings Continue Even After the Pandemic?

Two New Bills Could Ease California's Teleconferencing Restrictions for the Long-Term

As a result of the COVID-19 pandemic, the California Legislature previously passed AB 361 to allow for streamlined teleconferencing under the Brown Act during times of local emergency. Over time, public agencies and the general public have become more comfortable with fewer teleconferencing rules and restrictions. There are now two new bills that, if signed into law, would provide agencies with greater ease and streamlining in teleconferencing for the foreseeable future.

AB 1944 – Simple Approach Allowing For Broader and More Flexible Teleconferencing

AB 1944 would provide continued privacy to members of legislative bodies who are teleconferencing from private locations. The following requirements would apply:

- Legislative bodies must provide the public with virtual access when teleconferencing;
- Agendas must identify the members of the legislative body who will participate remotely;
- Legislative bodies must update agendas if members make last-minute decisions to teleconference;
- Legislative bodies must provide the public with a live video stream and an option to submit virtual public comments; and,
- A quorum must participate from within the agency's boundaries when teleconferencing, except under limited circumstances.

AB 1944 would authorize the legislative body to exempt itself by majority vote from the requirements that each teleconference location must be accessible to the public, and that their teleconference address be publicly identified in the notice and agenda. However, these exemptions would only apply when members of the legislative body teleconference from a non-public location (e.g. their home, a hotel, a hospital, etc.).

AB 1944 contains a Jan. 1, 2030, sunset for these provisions.

ROBERT H. JAMES

ATTORNEY AT LAW

ROBERT H. JAMES, Esq.
roberthjameslaw@gmail.com

3668 KATIE LENDRE DRIVE
FALLBROOK, CALIFORNIA 92028

TELEPHONE
(760) 723-9018

AB 2449 – More Complex Approach Allowing For Limited Teleconferencing

AB 2449 presents a more detailed approach to provide for similar goals as AB 1944. Generally, it only allows for relaxed teleconference rules “when a quorum of members participate in the meeting from a single public location,” meaning relaxed teleconferencing is only available to some members of the legislative body. So far, this bill has been less active than AB 1944.

AB 2449 would authorize relaxed teleconferencing procedures (meaning there would be no need to identify each teleconference location, post agendas at all teleconference locations, or allow the public to access the teleconference locations) if at least a quorum of the legislative body participates in-person at a single location identified on the agenda that is open to the public, and the legislative body follows certain requirements, including:

- Giving regular notice of the meeting and posting agendas as otherwise required by the Brown Act;
- Teleconferencing members must use both audio and visual technology;
- Allowing the public to access the meeting and provide comments, including by teleconference, and including teleconference instructions in all notifications and agendas for the meeting on how the public can attend and provide comment;
- Pausing the meeting when there is any teleconference disruption;
- Allowing for real-time public comments and not requiring submission of comments in advance of the meeting; and,
- Creating and implementing a procedure for receiving and swiftly resolving requests for reasonable accommodations for individuals with disabilities, and giving notice of this procedure in notifications and agendas for the meeting.

AB 1944 and AB 2449 remain active and have potential to become law. I will continue to track the progress of these bills and provide updates as appropriate.

ROBERT H. JAMES, Attorney at Law



Robert H. James, General Counsel for the
North County Fire Protection District

RHJ/klm
cc: Chief McReynolds



**NORTH COUNTY FIRE
PROTECTION DISTRICT
FIRE CHIEF/CEO**

TO: BOARD OF DIRECTORS
FROM: KEITH MCREYNOLDS, FIRE CHIEF/CEO
DATE: MAY 24, 2022
SUBJECT: WRITTEN CORRESPONDENCE

- **WRITTEN COMMUNICATION:** None.
- **BOARD RECOGNITION PROGRAM:** None.

PAGE INTENTIONALLY BLANK



California Special Districts Association
Districts Stronger Together

[CONTACT US](#) [JOIN](#) [SUPPORT](#)



[LOGIN](#)

Blog Viewer

[← BACK TO BLOG LIST](#)

Effort to Limit Revenues for Local Government Services Set Back to 2024

By Vanessa Gonzales posted yesterday

0 LIKE

Proponents of Initiative #21-0042A1, which would limit revenues for local government services, have announced they will not meet the deadline to qualify for the November 2022 ballot but will continue pursuing qualification for the November 2024 election. To qualify for the 2024 statewide ballot, proponents must submit 997,139 valid signatures by August 2, 2022.



Sponsored by the California Business Roundtable, Initiative #21-0042A1 would adopt new and stricter rules for raising taxes, fees, assessments, and property-related fees. The initiative seeks to amend the State Constitution, including portions of Propositions 13, 218, and 26 among other provisions, to the advantage of the initiative’s proponents and plaintiffs. If enacted, public agencies would face a drastic rise in litigation that could severely restrict their ability to meet essential service needs.

Contact ... ctu

Dubbed the “Taxpayer Protection and Government Accountability Act” by its proponents, Initiative #21-0042A1 is formally titled: “Limits Ability of Voters and State and Local Governments to Raise Revenues for Governments Services.” Thus far, proponents have raised over \$10 million and spent over \$8 million to qualify the initiative. They claimed to have reached 25 percent of signatures required on March 16, 2022.

On January 21, 2022, CSGA’s Board of Directors adopted an Oppose position on Initiative 21-0042A1 and has called on all special districts to join the growing coalition of community leaders in opposition to the proposal. Thus far, over 100 local governments, labor and public safety leaders, and infrastructure advocates have formally opposed the initiative, including over 25 special districts.

To learn more about Initiative 21-0042A1 and download a sample opposition resolution that your special district can adopt, please visit [csga.net/take-action/voterlimitations](https://www.csga.net/take-action/voterlimitations).

#AdvocacyNews

#FeatureNews

#Revenue

#PropertyTaxes

#SpecialTaxes

#Fees

0 comments

343 views

Permalink

<https://www.csga.net/blogs/vanessa-gonzales/2022/05/17/effort-to-limit-revenues-for-local-government-serv>

Governor Newsom Presents \$300.7 Billion Blueprint Paving the California Way Forward

Published: May 13, 2022

SACRAMENTO – As global inflation and war in Europe drive up costs across the country, California Governor Gavin Newsom is proposing a \$300.7 billion budget to provide relief from rising inflation, ensure public safety, address homelessness, transform public education, and combat climate change. The Governor’s California Blueprint includes an \$18.1 billion inflation relief package to get money back into the pockets of Californians and bring down costs for families.

“Backed by a robust surplus and grounded in our unshakable values, we’re paving the California Way forward to prosperity and progress for all. With historic investments, we’re doubling down on our formula for success and making sure no one is left behind – supporting working families and businesses, tackling climate change, expanding health care access, making our communities safer, and more,” said Governor Newsom. “While gridlock persists in Congress and right-wing fanatics turn statehouses across the country into laboratories of hate and oppression, here in California, we’re putting in the work to grow our economy and implement real, inclusive policy change to create a brighter future for all.”

- [\\$18.1 Billion Inflation Relief](#) in direct payments to help address inflation, help people pay their utility bills and rent, and reduce costs like health care and child care.
- [\\$47.1 billion climate commitment](#) – an increase of \$32 billion this year – to tackle pollution, build climate resilient water supplies, reduce the risk of catastrophic wildfires, ensure grid reliability and accelerate clean energy solutions, and protect communities from extreme heat.
- [\\$660 million to ensure public safety](#) with funding for new officers and mental health support for law enforcement, support for victims of sex trafficking, cracking down on internet crimes against children, and tackling the opioid crisis.
- [\\$14.7 billion to confront homelessness and the mental health crisis](#) with investments to help get people off our streets and into the services and care they need, focusing particularly on Californians who suffer from mental health and substance use disorders.
- [\\$37 billion to rebuild California](#) with money for infrastructure including broadband and new housing, as well as a historic investment of \$128.3 billion to transform public education.
- [Billions of dollars to invest in Californians and the Governor’s pro-life agenda](#), including funding to:
 - Improve our education systems with universal preschool, after school and school meals; and expanded, more affordable child care
 - Make health care more accessible and affordable through Medi-Cal expansion and subsidies, increased reproductive health care access, home visiting, and support for black infant health, youth mental health and suicide prevention, and addressing adverse childhood experiences.
 - Clean up our environment by tackling pollution, particularly in disadvantaged communities that bear the brunt of its impacts.
 - Ensure our communities are safe with violence prevention programs, expansive gun buyback programs and getting fentanyl and other opioids off our streets.

Led by GDP growth of 7.8 percent, the Blueprint includes a \$97.5 billion surplus. The Governor’s proposal ensures that this year’s spending will not hamstring future budgets, calling for \$37.1 billion in reserves including \$23.3 billion for the state’s Rainy Day Fund, and spends 94 percent of surplus revenues on one-time expenditures.

For further information on these and other items in the California Blueprint, visit www.ebudget.ca.gov.

###

Select Language ▾

Powered by Google Translate

Village News - Also serving the communities of De Luz, Rainbow, Camp Pendleton, Pala and Pauma

Fire disrupts Slurpy business at 7-11

By [Karen Ossenfort](#)

Other fires reported throughout the area

An early Sunday morning fire at the 7-11 at Main and Fallbrook Street, was quickly extinguished.

A call went out around 5:30 am when a 7-11 employee heard a pop and smelled smoke and called the fire department, said North County Fire Protection District spokesman John Choi.

Turns out the Slurpy machine wiring overheated and ignited. Firefighters were there quickly and prevented the fire from spreading. They removed the Slurpy machine.

Overnight, at Highway 76 and Pankey Road there was a single-vehicle accident that caused the vehicle to go off the road.

The driver was able to self-extricate from the vehicle and get away from it, Choi explained. The fire department and driver waited for a tow truck.

Another call came in Saturday night from Bonsall residents about an odor. Choi said they were smelling smoke from the Deer Springs vegetation fire, which started last night.

CalFire is handling the Deer Springs fire.

Connect With Us

Village News

111 W. Alvarado St.

X

63°

LIVE

BREAKING NEWS

1 killed, 4 'critically wounded' in Orange County church shooting, sheriff says

5 minutes left



LOCAL

Local fire crews help battle Laguna Niguel blaze

by: [Sir Milo Loftin](#)

Posted: May 12, 2022 / 02:57 PM PDT

Updated: May 12, 2022 / 06:42 PM PDT

SHARE    ...

LAGUNA NIGUEL, Calif. — Fire crews from San Diego County have made the drive up to Laguna Niguel to aid crews battling a destructive fire that has prompted a response from

agencies all across Southern California.

Fanned by offshore winds, a brush fire, dubbed the Coastal Fire, exploded in the Orange County city Wednesday, consuming nearly 200 acres and burning two-dozen homes. The fire was 0% contained as of Thursday afternoon, fire authorities said.

Coastal Fire burns homes, consumes 200 acres in Laguna Niguel >

San Diego Fire-Rescue department has two battalion chiefs and one four-person crew aiding at the Coastal Fire, said SDFD Public Information Officer Mónica Muñoz. They also have crews at the Hermit Peaks fire in New Mexico and a captain at the Crooks Fire in Arizona.

San Diego Fire Capt. Joe Amador told FOX 5's Jason Sloss that his crew arrived late Wednesday night to help relieve the local crews.

"We've been here ever since trying to support their mission, which is basically just to patrol and protect ... some of the remaining structures," he explained.

"We find it, you know, honorable to come up to another community and come help," Amador continued. "For us to come up here means that we can turn around, if something happened to San Diego, they'll be willing to come back and help us should the need arise."

North County Fire Protection District has two strike teams in Laguna Niguel made up of multiple agencies around North County San Diego, Public Information Officer John Choi said.

TOP STORIES

- | **Where are San Diego renters looking to move?**
- | **Scientists uncover possible cause of SIDS**
- | **Lottery ticket with five numbers sold in San Diego**
- | **Identity released of man found dead in downtown jail**

The first strike team is in conjunction with Vista Fire Department. The second team consists of crews from Rancho Santa Fe Fire Protection District, Pala Fire Department and Rincon Fire Department. In total, the North County Fire teams consist of 27 personnel.

SoCal Edison reports 'circuit activity' around time of destructive Laguna Niguel fire



Heartland Fire Rescue Department, which handles fire protection coverage for the cities Lemon Grove, La Mesa and El Cajon, also has crews on the scene.

Heartland Fire sent one Cal OES brush engine from La Mesa with 4 firefighters, one engine from El Cajon with 3 firefighters and one chief officer to assist the Orange County blaze, according to Heartland Fire Emergency Preparedness Coordinator Andy McKellar.

Fire crews from the South Bay have also gotten the call to head north to the Orange County fire.

Chula Vista Fire sent four firefighters as part of a OES type III strike team, according to CVFD Fire Captain Josh Sanders. National City Fire Department said in an [Instagram post](#) that they sent an OES engine to assist as part of a Metro Zone strike team.

Cal Fire San Diego and Carlsbad Fire Department crews have been spotted at the Coastal Fire scene.

Orange County Fire Authority officials are expected to give an update during a news briefing at 5:00 p.m. Thursday.

It is unknown at this time how long San Diego-area fire crews will be needed at the fire scene.

[Suggest a Correction](#)

NEWS > CRIME AND PUBLIC SAFETY • News

Camp Pendleton firefighters contain 657-acre vegetation fire



A fire that had burned over 600 acres on Camp Pendleton by Tuesday evening, May 10, was caused during a routine training exercise. (Photo courtesy of Camp Pendleton)

By **QUINN WILSON** | qwilson@scng.com |

PUBLISHED: May 10, 2022 at 9:15 p.m. | UPDATED: May 11, 2022 at 11:00 a.m.

A 657-acre vegetation fire at Camp Pendleton producing smoke plumes in Southern California was contained Tuesday evening, May 10.

The fire was reported around 4:40 p.m. around the U.S. Marine Corps. training facility's Romeo 3 training area, east of San Onofre State Beach, said Camp



The fire's smoke was likely visible from the 5 Freeway in parts of Orange and San Diego counties, according to the California Highway Patrol.

The Camp Pendleton Fire Department battled the blaze and was patrolling the area throughout the night.

[Newsroom Guidelines](#)



PUBLIC SAFETY

Be Prepared for Wildfires!



By **Chuck Westerheide**, County of San Diego Communications Office
May 2, 2022 | 6:43 PM

The County of San Diego joined CAL FIRE and partner agencies at the Ramona CAL FIRE Air Attack Base today to explain what you can do to prepare for wildfires. Almost half of the state's largest and most damaging wildfires occurred in 2020 and 2021, burning almost 7 million acres. But there are proactive steps you can take to prepare your home and communities to be more resilient to the impacts of wildfire.

- Create defensible space around your property by maintaining your lawn and removing combustible debris from around your home.
- Harden your home by using fire resistant materials for construction, renovation and landscaping to help protect your property.
- Make and share a family wildfire emergency plan. Talk to your neighbors about wildfire safety and plan how the neighborhood can work together before and after a wildfire.

“San Diego County is prepared, and we are ready to respond to wildfires,” stated Board of Supervisors Chair Nathan Fletcher. “Since the devastating 2003 Cedar Fire, your County has invested more than \$600 million. Those investments have improved fire protection and EMS, added staffing, fire stations, made communication enhancements, increased training and brush management. We’ve also added more ground and air equipment.”

Supervisor Joel Anderson said, “Some of the things we can do is really focus on the grants to help people harden their homes which we’ve done. We’ve all voted to spend \$1 million towards that goal. We also worked so that when you need to evacuate a place like Ramona, Alpine or Fallbrook the roads aren’t restricted. We’ve cut back all the trees along the evacuation routes, so people have a chance to get out.”

The event was the first of a statewide campaign to help Californians prepare for wildfires. The CAL FIRE Director was there to speak and show off some of the agency’s newest equipment. He was joined by representatives from the California Natural Resources Agency, United States Forest Service, California Office of Emergency Services, the California Military Department, the Highway Patrol and the CAL FIRE San Diego Fire Chief, Tony Mecham.

Chief Mecham praised all local fire crews, “San Diego County is unique, and I believe we are one of the most prepared regions in the United States. And the reason that we are so prepared is we have a mindset of collaboration and cooperation.”

To learn more about wildfire safety and preparedness, visit [readysandiego.org](https://www.readysandiego.org).



SHARE

TRENDING Today in San Diego Podcast Coronavirus Declared Endemic in Mexico Local ...

FALLBROOK

Crash Causes Power Outage, Car Fire in Fallbrook; 90 Customers Still Affected

As of 5:30 a.m., the number of customers without power dwindled to 90, with restoration expected to be completed by 11 a.m.

By **Rafael Avitabile** • Published April 25, 2022 • Updated on April 26, 2022 at 6:28 am

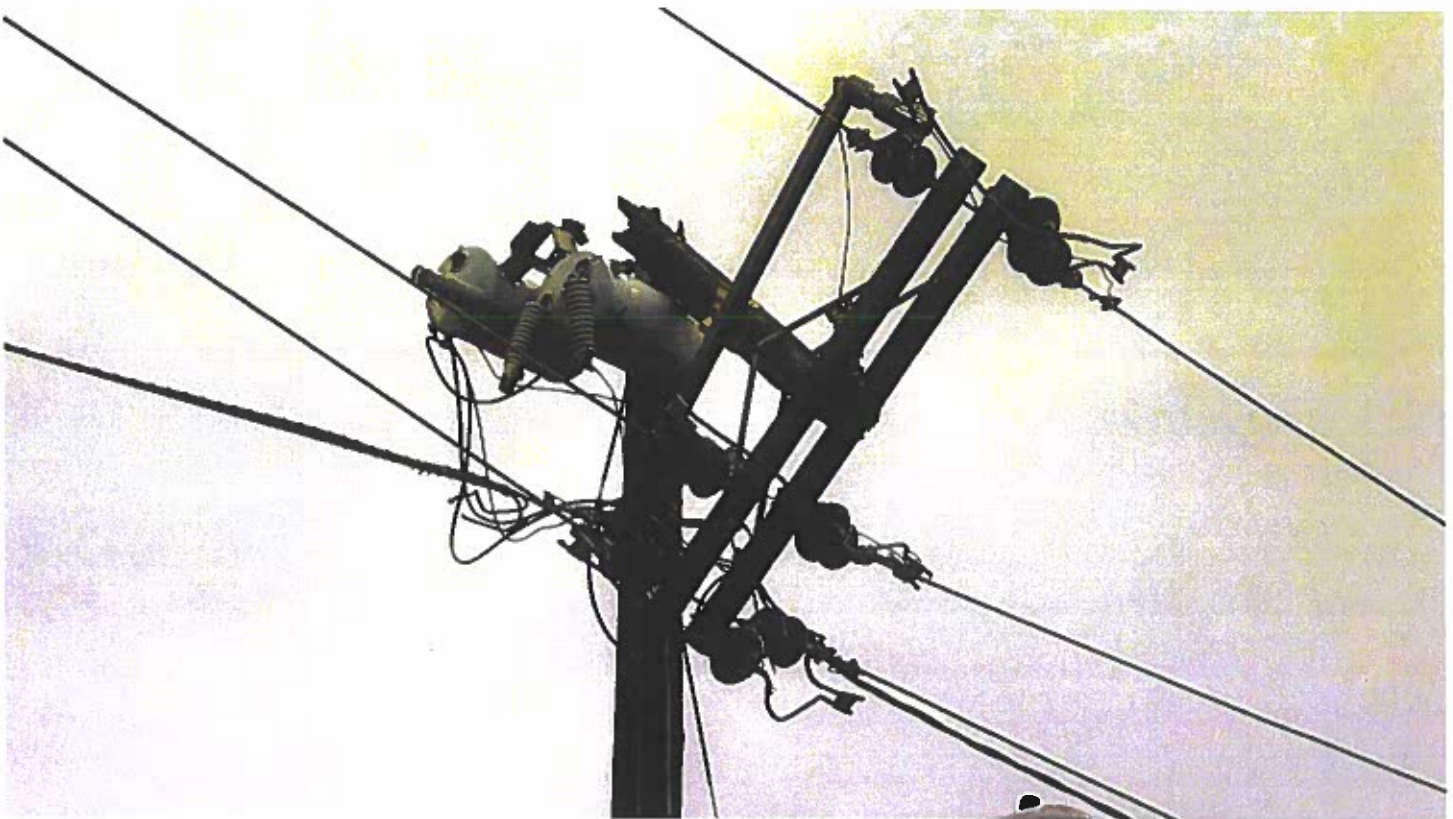

A car crash in Fallbrook left around 1,000 customers without power in Fallbrook Monday night, according to the North County Fire Protection District (NCFPD).

By Tuesday morning, power has been restored to the majority of about 1,000 customers who were left in the dark after a car crashed into a pole on Old Stage Lane, NCFPD said.

San Diego Gas and Electric's [online outage map](#) showed close to 1,000 customers in the area were without power at about 10 p.m. Monday.

.@NorthCountyFire is on scene of a traffic collision in the area of the 700 block of Old Stage Lane in Fallbrook. A power line pole was damaged. You may experience a power outage near this incident. pic.twitter.com/6PbAjeEeKf

— North County Fire Protection District (@NorthCountyFire) April 26, 2022

Stay informed about local news and weather. Get the NBC 7 San Diego app for iOS or Android and pick your alerts.

As of 5:30 a.m., the number of customers without power dwindled to 90, with restoration expected to be completed by 11 a.m.

A car set fire following the crash, the NCFPD said. Drivers were asked to avoid the area.

Check back for updates to this story.

This article tagged under:

FALLBROOK

CCPA Notice

SPONSORED · CAPITAL ONE SHOPPING

Coronavirus spiking in California as BA.2 variants spread

BY MICHAEL MCGOUGH
mmcgough@sacbee.com

A steady increase in coronavirus transmission has continued across most of California during April, recent state health data show, likely fueled by more contagious offshoots of the COVID-19 omicron variant that are gaining ground throughout the U.S.

California's daily case rate is now 8.7 per 100,000 residents, with test positivity at 2.7%, the California Department of Public Health said in a Tuesday update. Each metric is up about 40% in the past two weeks.

CDPH last Friday reported positivity at 3.1% but in Tuesday's update revised that day's figure to 2.8%. It still marked the state's highest measurement since Feb. 25, after falling as low as 1.2% in late March.

Wastewater monitoring data has shown potentially steeper increases in some well-populated parts of California.

The amount of virus detected in wastewater increased by about 192% in Davis between April 1 and April 17, and by about 140% in Sacramento in the same period, according to CDPH's wastewater network data dashboard.

During the same stretch, Yolo County's test positivity rate doubled and

Sacramento County's increased by about 50%.

There have also been significant increases in the Bay Area. Napa, San Francisco, Marin, Sonoma and Contra Costa counties all have test-positivity rates more than double the state average, ranging from 5.7% to 6.7%.

In San Jose, virus levels rose 150% in the wastewater from March 31 to April 16; test positivity spiked nearly 60% in the same stretch, CDPH infection numbers show.

Hospital numbers at the moment remain on a plateau. California on Tuesday reported 950 COVID-positive patients in hospital beds and has fluctuated between about 950 and 1,000 since April 15, state data show. The number of virus patients in intensive care units slid Tuesday to an all-time low of 112.

Both are tiny fractions of the omicron peak in early January, when California saw COVID-19 hospitalizations soar above 15,000 virus patients including 2,600 in ICUs.

Hospital trends throughout the pandemic have tended to lag behind case trends by a couple of weeks, though, meaning hospitalizations could begin to elevate soon given the increase in case rate. ICU numbers typically trail behind overall hospitalizations by an

additional week or so.

BA.2 SUBVARIANTS STILL ON THE RISE

U.S. health officials have estimated that BA.2 is roughly 40% more transmissible than the original omicron variant, BA.1; and that a related strain called BA.2.12.1 is about 25% more transmissible than BA.2, which would make it about 75% more contagious than BA.2.

The U.S. Centers for Disease Control and Prevention in a weekly update Tuesday said the two subvariants combined for 97% of U.S. virus cases last week, up from 93% the prior week. Of sampled cases nationwide, 68% were BA.2 and 29% were BA.2.12.1, compared to 74% and 19% one week earlier, respectively.

For the CDC region that comprises California, Arizona, Nevada, Hawaii and Pacific island territories, BA.2 made up 82% and the more contagious BA.2.12.1 comprised 15% last week, shifting from 85% and 9%, respectively, the previous week.

The precise prevalence of the two subvariants in California is not yet clear because the CDPH data dashboard for variants does not distinguish between BA.1, BA.2 and BA.2.12.1. All three subvariants remain lumped together as "omicron," which the state last week

said made up 99% of recent specimens sequenced for variants.

One Sacramento-area testing network that does monitor for BA.2, the Healthy Davis Together project in Yolo County, reported BA.2 comprised 93% of positive cases for the week ending April 16, with the remaining 7% BA.1.

BA.2 has increased from 83% on April 9 and 68% on April 2 in Yolo County. The rate of Healthy Davis Together tests returning positive increased by just over double between April 2 and April 16, according to the project website.

Healthy Davis Together data does not yet distinguish BA.2 from BA.2.12.1.

Experts are still working to understand BA.2 and BA.2.12.1, especially the latter, and how they may influence factors like vaccine efficacy and immune protection from previous infection.

Health officials across the U.S. have said in recent weeks that it does not appear that BA.2 causes more severe illness than the original omicron variant.

SACRAMENTO-AREA NUMBERS BY COUNTY

Sacramento County's latest case rate is 6.2 per 100,000 residents, state health officials said in a Tuesday update, a 35% increase from one week

earlier.

CDPH reported Sacramento's test positivity rate at 3.2% as of Tuesday, up from 2.7% last week.

Hospitals in Sacramento County were treating 48 virus patients Monday, state data show, down from 55 one week earlier. The ICU total halved, to four from eight.

The CDC classifies Sacramento County in the "low" level of COVID-19 activity.

Placer County's latest case rate is 5.2 per 100,000 residents, state health officials said in a Tuesday update, a 26% increase from one week earlier.

CDPH reported Placer's test positivity rate at 3.7% as of Tuesday, up from 3.5% last week.

Hospitals in Placer County were treating 22 virus patients Monday, state data show, down from 33 one week earlier. The ICU total moved to four from three.

The CDC classifies Placer County in the "low" level of COVID-19 activity.

Yolo County's latest case rate is 7.0 per 100,000 residents, state health officials said in a Tuesday update, a 9% increase from one week earlier.

CDPH reported Yolo's test positivity rate at 1.5% as of Tuesday, up from 1.2% last week.

Hospitals in Yolo County were treating one virus patient Monday, state data show, compared to two one week earlier. The ICU total held at zero.

The CDC classifies Yolo County in the "low" level of COVID-19 activity.

PUBLIC SAFETY

County Bolstering Aerial Fire Resources



BELL 412EPX

This is a sketch of the twin-engine Bell 412 EPX helicopter which the County will be purchasing for the Sheriff's Department fleet.

By **Yvette Urrea Moe**, County of San Diego Communications Office

Apr. 26, 2022 | 6:08 PM

The County Board of Supervisors voted unanimously Tuesday to strengthen aerial fire protection in the region by approving the purchase of a new twin-engine firefighting helicopter and adding two additional firefighting helicopters to a firefighting response agreement with San Diego Gas & Electric.

The Bell 412 EPX helicopter will be the first twin-engine in the Sheriff's fleet. A twin-engine helicopter is safer, can fly at night, hoist more weight, carry more water and reach more locations to pick up water.

“The reality is we need a twin-engine firefighting helicopter in our county firefighting arsenal. This has been a long-desired goal of making sure as a region, we’re better prepared to fight wildfires,” said Board Chairman Nathan Fletcher at the meeting. “We know over time we will need more than one but moving forward now with one is the right step as we confront the realities of much more devastating risk of wildfires than we’ve seen in the past and we upgrade our fleet air support arsenal.”

The San Diego County Sheriff’s Department firefighting and search and rescue helicopter **fleet** now consists of three Bell 205 helicopters built in the 1960s and 1970s. During wildfires, CAL FIRE/San Diego County Fire Protection District staff the helicopters, except for the pilot, for water drops. Eventually, all the Sheriff helicopters will be replaced with twin-engine models.

“It’s the next generation for ASTREA (Aerial Support to Regional Enforcement Agencies),” said Sheriff’s ASTREA Sgt. Gavin Lanning.

After a purchase is made, it typically takes 18 months for it to be delivered.

The Board also voted to amend an agreement with San Diego Gas & Electric to provide an additional two firefighting helicopters, bringing to five the number of helicopters available from the utility company to fortify an initial fire response. The agreement states that SDG&E pays for the first two hours of a new fire and the County pays for another two hours. In the event they are needed longer, the jurisdiction may choose to pay additional hours. Both SDG&E and the County have a \$150,000 annual contribution limit.

The SDG&E fleet includes two Sikorsky UH-60 Black Hawks, one Sikorsky S-64 Skycrane and one Airbus H145, with another Black Hawk to be added in 2023. All will be based in San Diego County and available to be assigned to local fires.

The County first entered into the agreement with SDG&E in 2009 and has renewed and expanded terms since then. In five years, the SDG&E helicopters have responded to 144 fires with 333 flight hours.

Related: **emergency** **firefighting helicopter** **preparedness**

Select Language ▼

Powered by [Google Translate](#)

Village News - Also serving the communities of De Luz, Rainbow, Camp Pendleton, Pala and Pauma

Firefighters make quick work of Fallbrook house fire

By [Kim Harris](#)
Managing Editor



North County Fire Protection District

A burned garage in the 1700 block of Tecolote Drive in Fallbrook shows the damage caused by a fire that broke out in the early afternoon hours Friday, April 15.

Firefighters made quick work of a house fire that broke out in a four-plex multi family dwelling in the 1700 block of Tecolote Drive in Fallbrook that was first reported at 12:18 p.m. Friday, April 15.

The fire, which broke out in a center unit, was contained by 12:40 p.m., North County Fire Protection spokesperson Captain John Choi said.

"We were able to contain the fire to the garage," Choi said. "The living area in the home was not affected."

Choi said it appeared the fire started in an attached garage on the front side of the home.

No one was injured in the blaze, Choi said.

X

Language 

Powered by  Google Translate

Village News - Also serving the communities of De Luz, Rainbow, Camp Pendleton, Pala and Pauma

NCFPD responds to 2 vehicle collision

By [Kim Harris](#)
Managing Editor

North County Fire Protection District responded to a two-vehicle accident that snarled traffic early this morning.

First reported around 7 a.m., Friday, April 22, the incident occurred in the area of South Mission and Olive Hill roads.

The roadway was closed due to a large amount of oil on the roadway NCFPD reported on Twitter.

“County roads is responding to assist with the oil spill,” the Tweet said.

After clean-up the roadway was re-opened to traffic.

Connect With Us

Village News

111 W. Alvarado St.
Suite 200
Fallbrook, CA 92028
Ph: (760) 723-7319

© 2022 Reeder Media, Inc.

Powered by [ROAR Online Publication Software](#) from Lions Light Corporation

© Copyright 2021

X

Select Language ▼

Powered by Google Translate

Village News - Also serving the communities of De Luz, Rainbow, Camp Pendleton, Pala and Pauma

NCFPD is adding an ambulance to the North San Diego Region



Village News/Courtesy photo

NCFPD Chief Keith McReynolds, fourth from right, and Vista Fire Chief Ned Vander Pol, third from right, shake hands on the placement of a NCFPD ambulance at Vista Fire Department Station 6. Village News/Courtesy photo

FALLBROOK – As of April 11, North County Fire Protection District placed an additional ambulance into service to help with the surge capacity of medical calls in the North San Diego County area. This ambulance is a Basic Life Support ambulance and will be responding out of Vista Fire Department Station 6, which is centrally located within the North San Diego area.

NCFPD has seen a large increase in 911 calls over the last couple of years and staff feel this additional ambulance will help meet the overall demands of their system. This is another great example of the district's collaboration and cooperation with its neighboring fire agencies to help build a safer community.

"We are so grateful for our partnership and the professionalism of Vista Fire Department. We look forward to proudly serving this community with them," said NCFPD PIO John Choi.

Submitted by North County Fire Protection District

X

PAGE INTENTIONALLY BLANK



**NORTH COUNTY FIRE
PROTECTION DISTRICT
FIRE CHIEF/CEO**

TO: BOARD OF DIRECTORS
FROM: KEITH McREYNOLDS, FIRE CHIEF/CEO
DATE: MAY 24, 2022
SUBJECT: COMMENTS, REPORTS AND UPDATES

● **STAFF COMMENTS/REPORTS/UPDATES:**

● **KEITH McREYNOLDS, FIRE CHIEF/CEO:**

● **CHIEF OFFICERS & STAFF:**

● **BOARD:**

● **BARGAINING GROUPS:**

● **PUBLIC COMMENT:**

PAGE INTENTIONALLY BLANK



**NORTH COUNTY FIRE
PROTECTION DISTRICT
FIRE CHIEF/CEO**

TO: BOARD OF DIRECTORS
FROM: KEITH McREYNOLDS, FIRE CHIEF/CEO
DATE: MAY 24, 2022
SUBJECT: CLOSED SESSION

CS-1. ANNOUNCEMENT — PRESIDENT EGKAN:

- An announcement regarding the items to be discussed in Closed Session will be made prior to the commencement of Closed Session.

CS-2. CONFERENCE WITH LABOR NEGOTIATOR – GOVERNMENT CODE § 54957.6 — MANAGEMENT GROUP NEGOTIATIONS – CHIEF McREYNOLDS:

- NCFPD MANAGEMENT GROUP
DISTRICT NEGOTIATORS:
CHIEF McREYNOLDS, DISTRICT COUNSEL JAMES

CS-3. CONFERENCE WITH LABOR NEGOTIATOR – GOVERNMENT CODE § 54957.6 — NON-SAFETY GROUP NEGOTIATIONS – CHIEF McREYNOLDS:

- FFA NON-SAFETY GROUP NEGOTIATORS
DISTRICT NEGOTIATORS:
CHIEF McREYNOLDS, DISTRICT COUNSEL JAMES

CS-4. CONFERENCE WITH LABOR NEGOTIATOR – GOVERNMENT CODE § 54957.6 — SAFETY GROUP NEGOTIATIONS — CHIEF McREYNOLDS:

- FFA SAFETY GROUP NEGOTIATORS
DISTRICT NEGOTIATORS:
CHIEF McREYNOLDS, DISTRICT COUNSEL JAMES

CS-5. EVALUATION OF PERFORMANCE – GOVERNMENT CODE § 54957:

- FIRE CHIEF/CEO
DISTRICT NEGOTIATOR:
DISTRICT COUNSEL JAMES

CS-6. EMPLOYMENT OF PUBLIC EMPLOYEE – GOVERNMENT CODE § 54957(b) — CHIEF McREYNOLDS:

- District Counsel

CS-7. REPORT FROM CLOSED SESSION — PRESIDENT EGKAN

PAGE INTENTIONALLY BLANK